

Contents

Safety Information	2
Electrostatic Discharge Sensitive (ESDS)	2
Specifications	3-6
Theory of Operation	7-11
Disassembly/Assembly Procedures	12-13
Figure 1. APC PCB, ESD Solder Points	12
Test Procedures	14-17
Figure 2. AM Test Setup	15
Part List Notes	18
Main Assembly Part List	19
Figure 3. System Exploded View	20
Electrical Part List	21-36
Packaging Part List	37
Figure 4. Packaging View	37
Abbreviated Operating Instructions	38
Figure 5. Keyboard Schematic Diagram	39

Manual Overview

The BWR/CD was originally manufactured with PCB 193325, PCB assembly 193321-1. Later version units were manufactured with PCB 252178, PCB assembly 252441-1. Service information for both versions is included in this manual.

[Product Image](#)

CAUTION: THE BOSE® WAVE® RADIO/CD CONTAINS NO USER SERVICE-ABLE PARTS. TO PREVENT WARRANTY INFRACTIONS, REFER SERVICING TO WARRANTY SERVICE STATIONS OR FACTORY SERVICE.

PROPRIETARY INFORMATION

THIS DOCUMENT CONTAINS PROPRIETARY INFORMATION OF BOSE® CORPORATION WHICH IS BEING FURNISHED ONLY FOR THE PURPOSE OF SERVICING THE IDENTIFIED BOSE PRODUCT BY AN AUTHORIZED BOSE SERVICE CENTER OR OWNER OF THE BOSE PRODUCT, AND SHALL NOT BE REPRODUCED OR USED FOR ANY OTHER PURPOSE.

WARRANTY INFORMATION

The Bose wave radio/CD is covered by a limited 1-year transferable warranty

SAFETY INFORMATION

1. Parts that have special safety characteristics are identified by the  symbol on schematics or by special notes in the part lists. Use only replacement parts that have critical characteristics recommended by the manufacturer.

2. Make leakage current or resistance measurements to determine that exposed parts are acceptably insulated from the supply circuit before returning the unit to the customer. Use the following checks to perform these measurements:

A. Leakage Current Hot Check-With the unit completely reassembled, plug the AC line cord directly into a 120V AC outlet. (Do not use an isolation transformer during this test.) Use a leakage current tester or a metering system that complies with American National Standards Institute (ANSI) C101.1 "Leakage Current for Appliances" and Underwriters Laboratories (UL) 1492 (71). With the unit AC switch first in the ON position and then in OFF position, measure from a known earth ground (metal water pipe, conduit, etc.) to all exposed metal parts of the unit (antennas, handle bracket, metal cabinet, screwhead, metallic overlays, control shafts, etc.), especially any exposed metal parts that offer an electrical return path to the chassis. Any current measured must not exceed 0.5 milliamp. Reverse the unit power cord plug in the outlet and repeat test. **ANY MEASUREMENTS NOT WITHIN THE LIMITS SPECIFIED HEREIN INDICATE A POTENTIAL SHOCK HAZARD THAT MUST BE ELIMINATED BEFORE RETURNING THE UNIT TO THE CUSTOMER.**

B. Insulation Resistance Test Cold Check-(1) Unplug the power supply and connect a jumper wire between the two prongs of the plug. (2) Turn on the power switch of the unit. (3) Measure the resistance with an ohmmeter between the jumped AC plug and each exposed metallic cabinet part on the unit. When the exposed metallic part has a return path to the chassis, the reading should be between 1 and 5.2 Meg ohms. When there is no return path to the chassis, the reading must be "infinite". If it is not within the limits specified, there is the possibility of a shock hazard, and the unit must be repaired and rechecked before it is returned to the customer.

ELECTROSTATIC DISCHARGE SENSITIVE (ESDS) DEVICE HANDLING

This unit contains ESDS devices. We recommend the following precautions when repairing, replacing or transporting ESDS devices:

- Perform work at an electrically grounded work station.
- Wear wrist straps that connect to the station or heel straps that connect to conductive floor mats.
- Avoid touching the leads or contacts of ESDS devices or PC boards even if properly grounded. Handle boards by the edges only.
- Transport or store ESDS devices in ESD protective bags, bins, or totes. Do not insert unprotected devices into materials such as plastic, polystyrene foam, clear plastic bags, bubble wrap or plastic trays.

SPECIFICATIONS

Physical Description

Dimensions: 14" W x 8.5" D x 4.375" H (35.6 x 21.6 x 11.1) cm

Weight: 7.4 lb (3.4 kg)

Enclosure: Injection molded thermal plastic

Power Specifications

Input Line Voltage: 120V, 60 Hz, 50W

Power Consumption: ≤ 8 W with unit switched off
≤ 50 W with CD player on, maximum output

CD Specifications

	Nominal	Limit	Conditions
Maximum output level	2.0 V	±2.0 dB	0 dB
THD + noise	.03%	.08%	1 kHz, -6 dB
Signal to Noise Ratio	95 dB	90 dB	A-weighted
Channel separation	80 dB	70 dB	1 kHz
Frequency response	±.5 dB	±1.0 dB	20 Hz-15 kHz
Low-level linearity error	5.0 dB	10.0 dB	-90 dB
De-emphasis	5 kHz	-4.53 dB	±2.0 dB
	16 kHz	-9.04 dB	±2.0 dB
Dynamic range	95 dB	90 dB	1 kHz, -60 dB, IEC-A, 20 kHz, LPF
Defect tracking (interruption)	1.0 mm	.8 mm	ABEX test disc TCD-725R
Defect tracking (black dot)	1.0 mm	.8 mm	ABEX test disc TCD-725R
Defect tracking (scratch)	1.6 mm	1.0 mm	ABEX test disc TCD-721R
Defect tracking (finger print)	75 μm	65 μm	ABEX test disc TCD-725R
Defect tracking (warped disc)	1.0 mm	.7 mm	ABEX test disc TCD-732RA
Defect tracking (eccentric disc)	280 μm	210 μm	ABEX test disc TCD-714R
Cueing time	2 sec	3 sec	Phillips TS4, tracks 1-15

Tuner Specifications

FM

FM Antenna: 75 Ohm external antenna connection, line cord functions as an FM antenna

Tuning range: US: 87.7 MHz-107.9 MHz
Euro: 87.7 MHz-108.0 MHz
Japan: 76.0 MHz-90.0 MHz

De-emphasis: US: 75 sec.
Euro: 50 sec.
Japan: 50 sec.

Frequency steps: US: 200 kHz
Euro: 50 kHz
Japan: 100 kHz

SPECIFICATIONS

FM Specification

(continued)

FM specifications per IHF-T-200, unless otherwise noted. Measurement conditions, unless otherwise noted: RF input frequency 98.1 MHz, audio frequency 1 kHz, RF input level 65 dBf, 75 kHz Deviation: Mono ± 75 kHz, stereo ± 67.5 kHz, ± 7.5 kHz pilot. The performance specifications listed below apply across the entire FM band.

Specification Parameter	Nominal	Limit (Ambient/ Environmental ¹)
Sensitivity usable (C1 removed) US: Euro: Japan:	13 dBf 14 dBf 13 dBf	17/23 dBf 19/25 dBf 17/23 dBf
Sensitivity usable (C1 present ³) US: Euro: Japan:	15 dBf 16 dBf 15 dBf	19/25 dBf 21/27 dBf 19/25 dBf
Stereo (50 dB quieting) US: Euro: Japan:	43 dBf 45 dBf 43 dBf	48 dBf 50 dBf 48 dBf
Signal to noise ratio at 65 dBf Mono: Stereo:	70 dBf 65 dBf	65/60 dBf 60/55 dBf
Signal to hum ratio at 65 dBf ² Mono: Stereo:	80 dBf 80 dBf	75 dBf 75 dBf
Harmonic distortion (1 kHz) at 65 dBf Mono: Stereo:	.3% .6%	.6/2.0% 1.0/2.0%
Harmonic distortion (1 kHz) at 65 dBf with ARI ⁴	.6%	1.5%
Capture ratio	3.0 dB	4.0 dB
AM rejection at 45 dBf	55 dBf	50 dBf
Adjacent channel selectivity US: Euro:	15 dB 15 dB	10 dB 10 dB
Alternate channel selectivity US: Euro:	65 dB 65 dB	60 dB 60 dB
Image rejection	46 dB	40 dB
RF intermodulation	60 dB	55 dB
Subcarrier product rejection at 65 dBf	45 dB	40 dB
Frequency response 30 Hz-15 kHz	1.0 dB	3.0 dB
Stereo channel separation at 1 kHz	30 dB	20 dB
Auto stop level (seek)	32 dBf	5/10 dBf
Mono/stereo threshold	42 dBf	5/10 dB

Table notes:

1: Environmental limits apply from =10 to +40C

2: Signal to hum ratio is defined as the ratio of signal to hum and its harmonics

3: To measure usable sensitivity with C1 present, configure power cord to run straight back from the unit for one foot and then straight downward for the remainder of the power cord's length. Use an EMI filter or other method to provide RF isolation at the wall outlet.

4: Use the standard European Broadcast Union ARI signal with 5 kHz signal on. DK signal on and BK signal code=F

SPECIFICATIONS

(continued)

AM

AM Antenna: Internal bar antenna, turn unit to optimize AM reception

Channel spacing: US: 10 kHz
Euro: 9 kHz
Japan: 9 kHz

Band Limits: US: 520 kHz-1710 kHz
Euro: 522 kHz-1611 kHz
Japan: 522 kHz-1629 kHz

Test Parameter	530-550 kHz	560-590 kHz	600-700 kHz	710-950 kHz	960-1400 kHz	1410-1610 kHz	1620-1710 kHz
Usable sensitivity, dB V/m, 200 Hz HPF	55/63/69 nominal/limit/ environmental	54/59/65 nominal/limit/ environmental	51/56/62 nominal/limit/ environmental	50/55/61 nominal/limit/ environmental	49/54/60 nominal/limit/ environmental	48/53/59 nominal/limit/ environmental	50/55/61 nominal/limit/ environmental
Adjacent channel selectivity, dB	42/37 nominal/limit	42/37 nominal/limit	40/35 nominal/limit	35/30 nominal/limit	35/30 nominal/limit	35/30 nominal/limit	35/30 nominal/limit
Alternate channel selectivity, dB	55/50 nominal/limit	55/50 nominal/limit	55/50 nominal/limit	55/50 nominal/limit	55/50 nominal/limit	55/50 nominal/limit	55/50 nominal/limit
Image rejection ratio, dB	45/40 nominal/limit	45/40 nominal/limit	45/40 nominal/limit	45/40 nominal/limit	42/37 nominal/limit	35/30 nominal/limit	35/30 nominal/limit
Signal to noise, dB, at 100 dB V/M	50/40/35 nominal/limit/ environmental	50/40/35 nominal/limit/ environmental	50/40/35 nominal/limit/ environmental	50/40/35 nominal/limit/ environmental	50/40/35 nominal/limit/ environmental	50/40/35 nominal/limit/ environmental	50/40/35 nominal/limit/ environmental
Distortion, %, at 100 dB V/M	.8/1.4/2 nominal/limit/ environmental	.8/1.4/2 nominal/limit/ environmental	.8/1.4/2 nominal/limit/ environmental	.8/1.4/2 nominal/limit/ environmental	.8/1.4/2 nominal/limit/ environmental	.8/1.4/2 nominal/limit/ environmental	.8/1.4/2 nominal/limit/ environmental
Frequency response, dB, at 50 Hz, 1.8 kHz, at 100 dB V/M	-3/-6 nominal/limit	-3/-6 nominal/limit	-3/-6 nominal/limit	-3/-6 nominal/limit	-3/-6 nominal/limit	-3/-6 nominal/limit	-3/-6 nominal/limit
Conducted susceptibility diff. mode, dB, min	20	20	20	20	20	20	20
Com. mode, dB, min	25	25	25	25	25	25	25
Auto stop level, dB V/M	56	56	56	56	56	56	56

SPECIFICATIONS

(continued)

Audio

THD at amplifier output:	<.2% at 1 kHz, at 80% of maximum output
THD at line output:	<.2% at 1 kHz, 2.0 Vrms AUX input
Auxiliary input sensitivity:	400 mVrms at 1 kHz for full output. 2.0 Vrms maximum auxiliary input
Auxiliary input impedance:	20 k Ohms
Speaker output noise:	500 μ Vrms, maximum volume, inputs shorted
Signal to noise at line output:	85 dB
Volume control increments:	1.25 dB
Volume control range:	78.75 dB at 1 kHz

Miscellaneous

Battery backup:	9 V, lasts up to 24 hours (alarm only)
------------------------	--

THEORY OF OPERATION

Note: All reference designators between 0 and 50 refer to components in the power supply and power amplifier on sheet 1 of the schematic. All reference designators between 200 and 299 refer to components in the voltage regulation section on sheet 2 of the schematic. All reference designators between 300 and 399 refer to components in the tuner section on sheet 3 of the schematic. All 400 series components are located on the Micro Controller PCB, shown on sheet 4 of the schematic. All reference designators between 500 and 599 refer to components in the CD section on sheet 5 of the schematic. All reference designators between 600 and 699 refer to components in the audio section on sheet 5 of the schematic.

1.0 Overview

The Wave® Radio/CD is an AM/FM tuner, single disk CD player, and powered speaker system. In addition to the internal sources, external devices such as a tape deck can be connected through the unit's AUX input. An infrared (IR) remote control can be used to control the unit.

2.0 Power Supply Electronics

AC mains are connected through the line cord attached to the polarized jack J1. The neutral wire of the line cord is used as an FM antenna coupled by C1. L1 and L2 provide isolation between the FM RF input and the transformer T1. A slow acting fuse F1 is connected between J1 and the non-polarized jack J2 to protect against faults.

Transformer T1 is a round core (R-core) transformer with one primary winding (unique for different AC mains voltage requirements) and three secondary windings. The primary has a series thermal fuse to protect against overload and faults. Two of the three secondary windings have center taps. Polarized jack J3 ensures the correct connection of the pins from T1.

The first secondary winding of T1 provides the main audio power V and the CD motor power VMOTOR. Bridge rectifier BR1 serves dual-purposes: it full wave rectifies the AC from two ends of the first secondary (without the center tap) (creating V when filtered by C6; part of it also rectifies through the center tap creating VMOTOR (about V/2)) when filtered by C16. The quiescent voltages of V and VMOTOR are about 15VDC and 7.5VDC, respectively. V provides power to the uC electronics (+5V) and the CD electronics (+5VCD). A 9V battery connected to J200 also provides backup power for the uC in case of a power outage. The switching between V and BAT+ is automatic through D207. +5V is regulated by U202, a voltage regulator with low dropout voltage and low quiescent current characteristics. Such characteristics are necessary to extend the battery life. +5VCD is regulated by U203. R212 is a dissipating element for U203.

The second secondary winding of T1 provides power to the audio and RF electronics: a positive voltage rectified by D201 and filtered by C205; and a negative voltage rectified by D200 and filtered by C202. The positive voltage is regulated by U201 to generate +10V for the audio electronics. R208 is a dissipating element for U201. The uC controls +10V and +5VCD through Q207, D202, Q206 and Q208. In the off mode and battery backup mode the uC releases TURNON, turning off Q206 and Q208 and consequently +10V and +5VCD. In any other mode the uC asserts TURNON. The negative voltage is regulated by U200 to provide -15V for the audio electronics. A reference voltage of -20.6V is created by the 5.6V zener diode ZR200 and R201 between -15V and the negative voltage. This -20.6V reference is buffered by Q202 to make -20V for the VFD electronics. The VFD "center tap voltage" CT is generated from -15V by Q201. The uC controls the brightness of the VFD partly by changing the CT voltage. It does so through AUD-DATA, Q210 and the resistor network R231 and R232. AUD-DATA from the uC is multiplexed and filtered by R230 and capacitor C231. Normally in a bright environment, AUD-DATA is filtered to be high so Q210 is turned off. The base of

THEORY OF OPERATION

Q201 is at the same voltage as -15V. Consequently CT is at about -14.4V. In a dark environment, AUD-DATA is filtered to be low so Q210 is turned on. The presence of +5V at the resistor network changes the voltage at the base of Q201. CT is increased to about -9V, consequently reducing the display brightness.

The third secondary winding of T1 provides AC power to the VFD filaments. It is nominally 5.3VAC. The center tap is connected to CT so that the VFD filaments are negatively biased.

R200 is used to protect Q201 at power up. R207, R211 and R214 are fusible resistors protecting against faults.

A line frequency signal (60 Hz) is generated from the secondary MAIN. MAIN is filtered by R205 and C215, clamped by D206, and buffered by Q200. 60 Hz (60 Hz or 50 Hz depending on the AC mains) is used by the uC to keep time and to detect a power failure.

3. Control Electronics

The embedded micro-controller (uC) used in this system is a Toshiba TMP87xx14F, where the xx digits define whether it is an OTP or a masked part. The main system power supply and the battery are connected to a low dropout low quiescent current regulator through D207; when the main power supply drops below the battery level, the battery will drive the uC. U403 is an automatic reset chip that monitors the 5 volts at the uC and will pull pin 29 of the uC (RESET) low if the voltage drops below 4.75 volts; it also supplies the power-on reset pulse. CF401 is an 8.00 MHz ceramic resonator with built in capacitors.

U401 is an Electrically Erasable Read Only Memory that is used to store presets, AM and FM stop levels, the stereo threshold level and other pieces of data. All of the series resistors and shunting capacitors used on the signal lines leaving the uC are helping control conducted RF emissions from the uC. D401 is a light sensor that in combination with R420 provides a voltage related to the light level in the room. This voltage is read by the analog to digital converter at bit 7 of port 6 and is used in the VFD dimming algorithm. Q401 is the infrared detector that works with the IR remote. The series resistors and shunting caps tied to the pins of the VFD are used to control RF emissions. The shunting resistors connected to six of the VFD control lines are used to help discharge the VFD lines when those particular segments or grids are to be turned off. Q405 and Q406 increase the current drive for two grids.

KEYIN1 through KEYIN4 and KEYOUT1 through KEYOUT6 are routed to the button board through J403 and form a button matrix. Normally, the uC holds the KEYOUT lines low and pins 59 through 62 of the uC, which correspond to the KEYIN lines, will be pulled low through R468, R469, R470 and R430. The uC has internal 80k pull downs to -20 Volts on pins 59 through 62, so the voltage there will actually be less than 0. The transistors Q400, Q402, Q403 and Q404 are used for level shifting and current gain to overcome the resistance of the carbon ink button board. When a button is pressed, a KEYOUT line will pull current through the base of the corresponding KEYIN transistor and drive one of the pins on the uC high. The uC will now begin scanning the KEYOUT lines by pulling each line individually high one at a time. This way, when the KEYIN signal disappears the uC will know the corresponding KEYOUT line and which button in the matrix is pressed. The uC can now execute the desired command.

THEORY OF OPERATION

4.0 Audio Electronics

The two internal sources (CD and tuner) and the AUX input are routed to the audio multiplexer/volume control chip U605. U605 selects one of the three inputs and routes the signal to pins 7 and 17 (right and left). These two signals are AC coupled to J600 as Line Outputs. Q602 and Q603 buffer a signal (BUZZER) from the μ C that is summed with the left channel for use as an alarm. The left and right signals then pass through matching EQ sections using R655, R656, C645, C646 and R660, R657, C665, C666. These sections normally provide bass cut at loud volume settings. These EQ sections increase the deep bass for lower volume settings. This is the dynamic EQ for the product. The final stage of U605 is the volume control. U605 provides 80 dB of attenuation in 64 steps of 1.25 dB. The variable level signal is output on pins 24 and 25.

The audio signal is then split into two paths. The right and left signals are routed through U600 and one quarter of U601, which provide active filtering for the left (full range) speaker output. The right signal is also routed through three-quarters of U601 which provides active filtering for the right (Twiddler™) speaker output.

The two audio signals are fed to the power amplifier U1. U1 is a bridged stereo power amp used for the right and left channels. The U1 outputs are routed through J5 and J6 to the left and right drivers respectively. U1 also contains a clip detector that is output on pin 4. This signal (COMP) controls the bias current of U603. When the amplifier is clipping, the bias current of U603 is increased. The change in gain of U603 reduces the bass frequency response of the left channel EQ. This is the compressor for the product.

Q4 is an amplifier that is connected to the Twiddler. It amplifies the signal BUZZER only when the unit is not powered. The power for this comes from the nine-volt battery.

5. Tuner Electronics

There are two major ICs in the tuner section: U300, an AM/FM radio chip with a built in stereo demultiplexer, and U301, a Phase Lock Loop (PLL) chip. The main system embedded controller (μ C) talks to the PLL chip using signals AUD-DATA, PLL-DATA, AUD-CLK and PLL-CE. The μ C controls whether the tuner is in AM or FM mode by forcing pin 8 of the PLL either high or low; a low puts U300 in AM mode and disables power to the FM-TUNER and a high puts U300 into FM mode and turns on power to the FM-Tuner via Q300 and Q301.

In FM mode the frequency of the local oscillator (LO) located in the FM-TUNER is adjusted by the signal FM_TV which is applied to pin 5 of the FM-TUNER. The LO is then output on pin 8 and routed back to U301 via C338. The PLL then compares the scaled frequency/phase of the LO against a reference which is a division of the 7.2 MHz oscillator composed of U301, C341, C342 and CF303. The result of this comparison determines the density and polarity of the phase pulses which are output on pin 16 of U301. The phase pulses then go into the loop filter composed of a MOSFET inside of U301 (Ain and Aout) and the discrete components attached to pins 16, 17 and 18. The loop filter integrates the phase pulses to form the DC control voltage FM_TV thus completing the LO control loop.

Inside the FM-TUNER, the LO is mixed with the RF signal, coming from the F-Connector J300 or off of the AC line cord neutral wire via C1, to produce an IF signal centered at 10.7 MHz that is output on pin 7. The IF signal then passes through ceramic filter CF300, the common emitter amp containing Q303, CF301 and is then routed into U300. Inside the chip the IF signal is limited and detected. The resonant LC circuit on pin 9 is part of the detector circuit. After detection, the stereo signal is

THEORY OF OPERATION

then de-multiplexed inside the chip and the stereo channels are output onto pins 16 and 17. The ceramic resonator CF302 is used by the stereo de-multiplexer's VCO. C321, C320 and R315 form the loop filter for the de-multiplexer's PLL. The left and right channel signals are then routed through the 19 kHz pilot reject filters composed of T303 and T304. The μ C makes stop and stereo threshold decisions based on the level of the S-METER signal which is read by the analog to digital converter in the μ C. The μ C forces the radio into mono mode by telling U301 to force its pin 9 low.

For AM, the Local Oscillator is composed of the LC resonant circuit, which is half of D304 and T302, and an amplifier in U300. The AM LO signal comes out of pin 30 of U300 and is fed into U301 via R330 and C337. The PLL chip compares the scaled LO frequency against a division of the 7.2 MHz oscillator and outputs the appropriate phase pulses from pin 16 into the loop filter. The tuning voltage comes out of the loop filter through R309 and appears across pins 1 and 2 of the varactor diode to complete the AM LO control loop.

The inductance of the AM Bar Antenna at pins 3 and 4 form a parallel resonance with the capacitance between pins 3 and 2 of the varactor diode producing frequency selectivity at the antenna. The RF at pin 1 of the antenna is routed into pin 27 of U300. The input circuitry at pin 27 is biased to 3.6 volts (V_{reg}) through R308 and the coil wound between pins 1 and 2 on the antenna. Inside the chip, the RF is amplified and mixed down to an IF (intermediate frequency) of 450 kHz. The IF is output on U300 pin 2 and routed to the IF filtering in T301. The filtered IF then enters U300 at pin 5 and passed through audio detection in the chip. The audio is then output onto pins 16 and 17.

6.0 CD Electronics

The CD circuitry consists of four major sections: the analog signal processor (ASP) U500, digital signal processor (DSP) U501, power driver U502 and the CD mechanism. U500 contains the RF amplifier and servo control circuits. U501 performs EFM demodulation, CIRC decoding, digital filtering, D to A conversion and low-pass filtering. It also extracts the subcode Q data (track #, time, etc.).

U500 receives its input signal (through J500) from the mechanism's photo diode pickup. The inputs A, B, C and D are added together and amplified. The RF amplifier output appears on RFSM (U500, pin 41). This signal is the familiar eye pattern. This signal is sent to EFMIN on U501 pin 10 where it is sliced for EFM demodulation. The sliced output appears on EFMO (U501 pin 9). A low-passed version of this signal appears on SLC (U500 pin 43) and is used as a DC bias for the RFSM signal.

The RFSM signal is peak detected and compared to a reference to determine if there is a signal being received from the disc. The output appears on DRF (U500 pin 54). This signal is used by the μ C to determine if the lens is in focus. The envelope of the RFSM signal is used to determine when the laser crosses a track boundary during track access. The HFL signal (U500 pin 37) conveys this information to U501.

The B+D signal (FIN2) is subtracted from the A+C signal (FIN1). This produces the focus error signal FE (U500 pin 20). This signal is amplified and filtered by the focus servo amplifier within U500. It then appears as an output FD (U500 pin 16). The FD signal is fed to U502. U502 generates a bridged output which is used to actuate the focus coil (J500 pins 10 and 13).

The E and F signals are buffered by U500. E is then subtracted from F and this difference is the track error signal TE (U500 pin 7). TE is used by both the anti-shock circuit and the tracking servo. TE is filtered at the SCI input (U500 pin 9) to determine if the system has had a shock. If this occurs, U500 increases the track gain internally to compensate for the shock. The TE signal is amplified and filtered by the tracking servo amplifier within U500. It then appears as an output TO (U500 pin 15).

THEORY OF OPERATION

The TO signal is fed to U502. U502 generates a bridged output which is used to actuate the track coil (J500 pins 11 and 12).

The TO signal is also used as an input to the sled servo. This signal is filtered and fed to the sled servo amplifier on SLEQ (U500 pin 28). This signal is amplified and added to the SLED signals from the μ C. The sum appears on SLD (U500 pin 29), which is fed to U502. U502 generates a bridged output to drive the sled motor (J502 pins 5 and 6).

The Constant Linear Velocity (CLV) servo is regulated by comparing the bit rate to a fixed reference frequency in U501. The error signal appears at U501 pins 12 and 13 (CLV+ and CLV-). These signals are subtracted and the difference appears on SP (U500 pin 23). The SP signal is filtered and amplified. The signal then appears at the output on SPD (U500 pin 27). SPD is fed to U502. U502 generates a complimentary output which drives the spin motor (J502 pins 1 and 2).

U500 regulates the laser power by monitoring the LDS input (J500 pin 8). This signal is compared to a reference to generate the proper drive signal on LDD (U500 pin 62). This signal is buffered by Q500. The Q500 output is amplified by Q501. Q501 drives the laser diode output LD (J500 pin 6). U500's main DC reference voltage is VREF (U500 pin 58). This voltage is nominally 2.5V.

U500 receives servo control commands from the μ C on the serial bus (U500 pins 51, 52 and 53). These commands are used to start focus offset cancellation, track offset cancellation, E/F balance adjustment, focus initialization, laser ON/OFF and 8/12 cm spindle gain.

The DSP clock is derived from a 16.9344 MHz crystal oscillator (CF500). U501 divides this clock by four to generate a 4.2336 MHz signal that is output as the signal 4.2M (U501 pin 61). 4.2M is used as a system clock by the ASP.

U501 receives servo control commands from the μ C on the serial bus (U501 pins 57, 56 and 54). These commands include track jump, focus start, disk motor start/stop, muting on/off and track count. The tracking servo is controlled by the TOFF and TGL outputs (U501 pins 17 and 18). Track jumps are created by signals on the JP+ and JP- lines (U501 pins 19 and 20). Track jump detection is based on signals from U500 on the HFL and TES inputs. U501 removes the subcode Q data from the bit stream and makes it available to the μ C. The μ C extracts track, time and table of contents information from the subcode Q.

U501 receives its EFM input from U500 on EFMIN (pin 10). This signal is sliced, EFM demodulated and CIRC decoded. The digital audio signal is passed through a 4x over-sampling digital filter, D/A converter and low-pass filter. These outputs appear on RCHO and LCHO (U501 pins 40 and 37). The audio signals are routed to U605.

DISASSEMBLY/ASSEMBLY PROCEDURES

Note: The numbers in parentheses refer to the callouts in Figure 3.

1. Top Cover Removal

1.1 Remove the three screws (21) that secure the top cover (6) to the base (9).

1.2 Insert a flat blade screwdriver into the two locations shown in Figure 3. Apply force on the flat blade screwdriver so that the grille is moved outward and clears the two tabs located on the base.

1.3 Lift up on the top cover to remove it.

2. Top Cover Replacement

2.1 Lower the top cover (6) onto the base (9). Make sure that the ribbon cable that connects to the CD door (7) lays in the track to the left of the CD mechanism (2).

Note: The light shield (4) can get caught on the top cover. Make sure the light shield is secured in place when replacing the top cover.

2.2 With the palms of your hands located on the front corners of the top cover, press down on the top cover until it snaps into place.

2.3 Replace the three screws (21) that secure the top cover to the base.

3. Display PCB Removal

3.1 Perform procedure 1.

3.2 Lift up the display PCB (1).

3.3 Remove the ribbon cable that connects the CD door (7) to the display PCB. Remove the two ribbon cables that connect to the main PCB. Lift out the display PCB.

Caution: If you remove the ribbon cable from the CD door, you might have difficulties reconnecting the cable.

4. Display PCB Replacement

4.1 Replace the three ribbon cables that attach to the display PCB (1).

4.2 Lower the display PCB into the slots located on the matrix assembly (8).

5. CD Mechanism Removal

5.1 Perform procedure 1.

5.2 Lift up the CD mechanism (2) and solder the two points located on the CD mechanism's APC PCB. See Figure 1. This will prevent static electricity damage to the CD mechanism.

5.3 Remove the cables from the CD mechanism's and lift out the CD mechanism.



Figure 1. APC PCB, ESD Solder Points

6. CD Mechanism Replacement

6.1 Attach the cables to the CD mechanism (2) and remove the solder from the two points indicated in Figure 1.

6.2 Lower the CD mechanism into the matrix assembly (8) so that the cables are toward the right speaker.

7. Twiddler™ and Full-Range Driver Removal

7.1 Perform procedure 1.

7.2 Remove the four screws (18) that secure the Twiddler/full-range driver (3, 4) to the matrix assembly (8). Pull out the driver from the matrix assembly and remove the soldered wires from the driver.

DISASSEMBLY/ASSEMBLY PROCEDURES

8. Twiddler™ and Full-Range Driver Replacement

8.1 Solder the red wire to the positive (+) driver terminal and the black wire to the negative (-) driver terminal.

8.2 Align the driver (3, 4) into the matrix assembly (8) so that the wires feed through the channel on the top of the matrix assembly.

8.3 Replace the four screws (18) that secure the driver to the matrix assembly.

9. Transformer Removal

9.1 Perform procedure 1 first.

9.2 Remove the three screws (17) that secure the transformer (5) to the matrix assembly (8) and lift up the transformer.

9.3 Remove the two wire connectors that connect to the main PCB (1).

10. Transformer Replacement

10.1 Connect the two wire connectors to the main PCB (1).

10.2 Lower the transformer (5) into the matrix assembly and replace the three screws (17) that secure the transformer to the matrix assembly.

11. Main PCB removal

11.1 Perform procedure 1 first.

11.2 Remove the two lower screws (17) that secure the transformer (5) to the matrix assembly (8). Remove the two screws (17) on the left side that secure the matrix assembly to the base (9).

11.3 Lift up the CD mechanism (2) and place it off to the side.

11.4 Lift up the display PCB (1) and lay it down in front of the unit.

11.5 Lift up the matrix assembly (8), disconnect the wire connectors from the main PCB (1) and lift off the matrix assembly. Make a note of the way the wires are dressed.

11.6 Disconnect the two ribbon cables that connect the main PCB to the display PCB. Lift up the main PCB.

12. Main PCB Replacement

12.1 Lower the main PCB (1) into the base. Make sure that the nine-volt battery connector is positioned properly in the battery compartment. Connect the ribbon cables from the display PCB (1) to the main PCB.

12.2 Partly lower the matrix assembly (8) onto the base and connect all the wire connectors to the main PCB and then completely lower the matrix assembly onto the base (9). Make sure the AC line cord is inserted into the notch on the base.

12.3 Replace the two screws on the left (17) that secure the matrix assembly to the base and the two screws (17) that secure the transformer (5) to the matrix.

12.4 Lower the CD mechanism into the matrix assembly (8) so that the cables are toward the right speaker.

12.5 Lower the display PCB into the slots located on the matrix assembly.

TEST PROCEDURES

General Test Setup Procedures

Twiddler™ channel: Connect an 8 Ohm \pm 1%, 10 W load to J6, pins 1 and 2. The Twiddler is the right speaker, when viewed from the front of the unit.

Full-range channel: Connect a 4 Ohm \pm 1%, 25 W load to J5, pins 1 and 2. The full range driver is the left speaker, when viewed from the front of the unit.

Adjust the volume to 64 unless otherwise noted.

Note: The door switch, located on the underside of the door, needs to be closed for the function buttons to work.

Audio Tests

1. Mute Test

1.1 Apply a 1 Vrms, 1 kHz signal to the left and right aux input.

1.2 Reference a dB meter to the Twiddler or full-range output.

1.3 Press the mute button. The Twiddler or full-range output should be $<$ -55 dB.

2. Channel Separation

2.1 Apply a 1 Vrms, 1 kHz signal to the left aux input and short the right aux input.

2.2 Reference a dB meter to the full-range output.

2.3 Measure the Twiddler output. It should be $<$ -50 dB.

3. Compressor Distortion

3.1 Apply a 200 mVrms, 150 Hz signal to the left and right aux input. Adjust the volume to 99.

3.2 Measure the distortion at the full-range output. It should be $<$ 5%.

4. DC Offset

4.1 Select the aux mode and short the left and right aux input.

4.2 Measure the Twiddler and full-range outputs. They should be $>$ -150 mVDC and $<$ +150 mVDC.

5. Full Range Channel Output Noise

5.1 $<$ 1.0 mV, A-weighted, inputs shorted.

6. Full-Range Channel Reference Gain

6.1 Apply a 15 mVrms, 1 kHz signal to the left and right aux input. Adjust the volume to 99.

6.2 Reference a dB meter to the applied signal.

6.3 Measure the full-range output. It should be $+22.0$ dB \pm 2.2 dB.

7. Full-range Channel Frequency Response

7.1 Apply a 15 mVrms, 1 kHz signal to the left and right aux input. Adjust the volume to 99.

7.2 Reference a dB meter to the full-range output.

7.3 Measure the full-range output according to the following table.

Frequency	Output
50 Hz	-8.3 ± 3.1 dB
90 Hz	$+16.5 \pm 2.4$ dB
300 Hz	$+4.8$ dB \pm 1.3 dB
500 Hz	-1.2 ± 1.1 dB
1.0 kHz	Reference
2.0 kHz	$+4.7 \pm 1.0$ dB
5.0 kHz	$+12.7 \pm 1.0$ dB
15 kHz	$+18.3 \pm 2.2$ dB

TEST PROCEDURES

8. Full-Range Channel Dynamic EQ Gain

8.1 Apply a 15 mVrms, 1 kHz signal to the left and right aux input. Adjust the volume to 49. Reference a dB meter to the full-range output.

8.2 Apply a 1.5 mVrms, 80 Hz signal to the left and right input.

8.3 Measure the full-range output. It should be $+3.5 \pm 1.0$ dB.

9. Full-Range Channel Small Signal Distortion at 0.1 W

9.1 Apply a 30 mVrms, 1 kHz signal to the left and right aux input. Adjust the volume to 99.

9.2 Measure the full-range output. It should be $<0.5\%$ THD.

10. Full-Range Channel Large Signal Distortion at 6 W.

10.1 Apply a 200 mVrms, 1 kHz signal to the left and right aux input. Adjust the volume to 99.

10.2 Measure the full-range output. It should be $<0.2\%$ THD.

11. Twiddler™ Channel Output Noise

11.1 Measure the Twiddler channel output. It should be <300 uV, A-weighted, inputs shorted.

12. Twiddler Channel Reference Gain

12.1 Apply a 50 mVrms, 1 kHz signal to the left and right aux input. Adjust the volume to 99.

12.2 Reference a dB meter to the applied signal.

12.3 Measure the Twiddler output. It should be $+20.5 \pm 2.0$ dB.

13. Twiddler Channel Frequency Response

13.1 Apply a 50 mVrms, 1 kHz signal to the left and right input. Adjust the volume to 99.

13.2 Reference a dB meter to the Twiddler output.

13.3 Measure the Twiddler output according to the following table.

Frequency	Output
200 Hz	-15.6 ± 1.3 dB
400 Hz	-4.6 ± 1.2 dB
550 Hz	-1.8 ± 1.0 dB
1 kHz	Reference
3 kHz	-3.7 ± 1.0 dB
10 kHz	$+9.1 \pm 1.0$ dB
20 kHz	$+6.6 \pm 1.5$ dB

14. Twiddler Channel Small signal Distortion at 0.5 W

14.1 Apply a 130 mVrms, 1 kHz signal to the left and right input. Adjust the volume to 99.

14.2 Measure the twiddler channel output. It should be $<0.1\%$ THD.

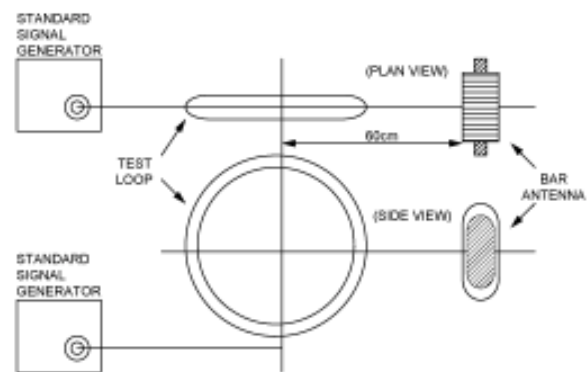

Figure 2. AM Test Setup

15. AM Tracking Alignment

15.1 Adjust the RF generator to 1500 kHz, 400 Hz, 30% AM modulation at a level of 70 dBuV/m at the unit's antenna.

15.2 Adjust C307 for peak audio output measured at the line output.

15.3 Adjust the RF generator to 600 kHz, 400 Hz, 30% AM modulation at a level of 70 dBuV/m at the antenna.

TEST PROCEDURES

15.4 Adjust T302 for peak audio output measured at the line output.

15.5 Adjust the RF generator to 1500 kHz, 400 Hz, 30% AM modulation at a level of 70 dBu/m at the unit's antenna.

15.6 Adjust C307 for peak audio output measure at the line output.

16. AM Sensitivity

16.1 Adjust the RF generator to 1080 kHz, 400 Hz, 30% AM modulation at a level of 53 dBuV/m at the unit's antenna.

16.2 Reference a dB meter to the aux output.

16.3 Turn off the modulation and measure the aux output. It should be < -20 dB.

17. AM Stop Level Adjustment

17.1 Adjust the RF generator to 1080 kHz, no modulation at a level of 59 dBuV/m at the unit's antenna.

17.2 Press the CD mode, AM and Alarm 2 buttons at the same time to store the AM stop level.

FM Tests

18. FM Detector Adjustment

18.1 Adjust the FM generator to 98.1 MHz (87.4 MHz for Japan), 1 kHz modulation, pilot off, 75 kHz deviation and at a level of 40 dBf into the antenna input.

18.2 If the THD measured at the line output is greater than .5%, adjust T300 until the THD is less than .5%. Verify the line output is 560 mVrms \pm 200 mVrms.

19. Stereo Separation

19.1 Adjust the RF generator to 98.1 MHz (87.4 MHz for Japan), 1 kHz stereo left only modulation, 10% pilot, 75 kHz deviation at a level of 65 dBf into the antenna input.

19.2 Reference a dB meter to the left line output.

19.3 Switch the RF generator to right only modulation. Verify that the left line output is \leq -25 dB.

20. FM Stop Level Adjustment

20.1 Adjust the RF generator to 98.1 MHz (87.4 MHz for Japan), no modulation at a level of 30 dBf into the antenna input.

20.2 Press the CD mode, FM and alarm 2 buttons at the same time to store the FM stop level.

20.3 Adjust the RF generator to 98.9 MHz (88.0 MHz for Japan), 1 kHz modulation, 75 kHz deviation at a level of 35 dBf into the antenna input. Press the seek button and verify the tuner stops at 98.9 MHz.

21. Stereo Threshold Adjustment

21.1 Adjust the RF generator to 98.1 MHz (87.4 MHz for Japan), 10% pilot, 75 kHz deviation at a level of 42 dBf into the antenna input.

21.2 Press the CD mode, FM and CD stop button at the same time to store the stereo threshold.

22. FM Sensitivity

22.1 Adjust the RF generator to 98.1 MHz (87.4 MHz), 1 kHz stereo L = R modulation, 10% pilot, 75 kHz deviation at a level of 48 dBf into the antenna input. Reference a dB meter to the line output.

22.2 Turn off the modulation and verify that the line out is \leq 50 dB (\leq 45 dB for European version).

TEST PROCEDURES

CD Tests

23. CD Performance Test

23.1 The BWR/CD should be able to play the tests discs listed in the following table for the amount of time stated without any audible defects. There are no CD adjustments that can be made to the BWR/CD. If the unit fails any of these tests, replace the CD mechanism.

Test	Disc	Test Conditions
Void, 1.0 mm	ABEX test disc TCD-725R	Track 6, 6 sec.
Black dot, .8 mm	ABEX test disc TCD-725R	Track 9, 8 sec.
Finger print, 65 um	ABEX test disc TCD-725R	Track 13, 10 sec.
Warped disc, 1.0 mm	ABEX test disc TCD-725RA	First and last track, 6 sec.
Eccentric disc, 210 um	ABEX test disc TCD-714R	First and last track, 6 sec.
Cueing time, 2 sec.	Phillips TS4, tracks 1-15	Skip first to last track
Long playability, 71' 42 "	ABEX test disc TCD-784	Last track, 6 sec.

PART LIST NOTES

1. This part is not normally available from customer service. Approval from the Field Service Manager is required before ordering.

2. The individual parts are listed in the part list.

3.  This part is critical for safety purposes. Failure to use a substitute replacement with the same safety characteristics as the recommended replacement part might create shock, fire and/ or other hazards.

4. This part is used on 120V version.

5. This part is used on 230V (EURO) version.

6. This part is used on 240V (AUS) version.

7. This part is used on 100V version.

8. This part is packed with the 100V version only. An antenna is not packed with the 120V version.



9. This part is used on PCB 193325, PCB assembly 193321-1

10. This part is used on PCB 252178, PCB assembly 252441-1

11. This part is used on PCB 253355

MAIN ASSEMBLY PART LIST

(refer to Figure 3)

Item Number	Description	Part Number	Qty.	Note
1	PCB ASSEMBLY, 120V PCB ASSEMBLY, 220V/240V PCB ASSEMBLY, 100V	252441-1	1	4 5, 6 7
2	CD MECHANISM, CD93V4M	193373	1	
3	FULL-RANGE TWIDDLER®, W/HARNESS, LEFT	145588-002	1	
4	TWIDDLER, W/HARNESS, RIGHT	148704-002	1	
5	TRANSFORMER, R-CORE, 120V, 60HZ TRANSFORMER, R-CORE, 230V, 50HZ TRANSFORMER, R-CORE, 100V, 50HZ	193372 250604 251780	1	3, 4 3, 5, 6 3, 7 
6	TOP COVER IMPERIAL WHITE TOP COVER, PLATINUM WHITE TOP COVER, GRAPHITE	198613-001 193391-010 193391-002	1	
7	DOOR ASSEMBLY, IMPERIAL WHITE DOOR ASSEMBLY GRAPHITE GRAY DOOR ASSEMBLY, PLATINUM WHITE	NOT AVAILABLE 198608-002 198608-010	1	
8	MATRIX ASSEMBLY, BLACK	193376-011	1	
9	PEDESTAL ASSEMBLY, BLACK	198614-001	1	
10	LENS, GREEN	193392-001	1	
11	SHIELD, LIGHT, CONTOURED	199608	1	
12	CABLE, FLEX, 21 CONDUCTOR	193394-100	2	
13	CABLE, FLEX, 13 CONDUCTOR	193374-100	1	
14	HARNESS, 6 CONDUCTOR	193375-001	1	
15	GROMMET, RUBBER, CUSHION, RED DOT	193382	1	
16	GROMMET, RUBBER, CUSHION, WHITE DOT	193380	2	
17	SCREW, TAPP, 8-11x.625, PAN, XRC/S	172672-10	6	
18	SCREW, HILO, 6x.5, PAN, XREC	175972-08	8	
19	LINE CORD, 120V, PLATINUM WHITE LINE CORD, 120V, BLACK LINE CORD, 230V, PLATINUM WHITE LINE CORD, 230V, BLACK LINE CORD, 240V, PLATINUM WHITE LINE CORD, 240V, BLACK LINE CORD, 100V, PLATINUM WHITE LINE CORD, 100V, BLACK	193395-010 193395-001 193396-010 193396-001 251967-010 251967-001 193404-010 193404-001	1	3, 4 3, 4  3, 5 3, 5 3, 6 3, 6 3, 7 3, 7
20	CABLE, FLEX, 15 CONDUCTOR	193384-100	1	
21	SCREW, TAP, 8-11X.625, PAN, XRC/SQ	193637-10	3	
22	ARM, SPRING	193329	1	
-	BATTERY DOOR, BLACK	193409-001	1	
-	CLIP, DAMPER	193428	1	
-	GEAR, DAMPER, WHITE	146816-04	1	
-	SPRING, EXTENSION	193379	1	
-	FELT FOOT	193460-001	4	

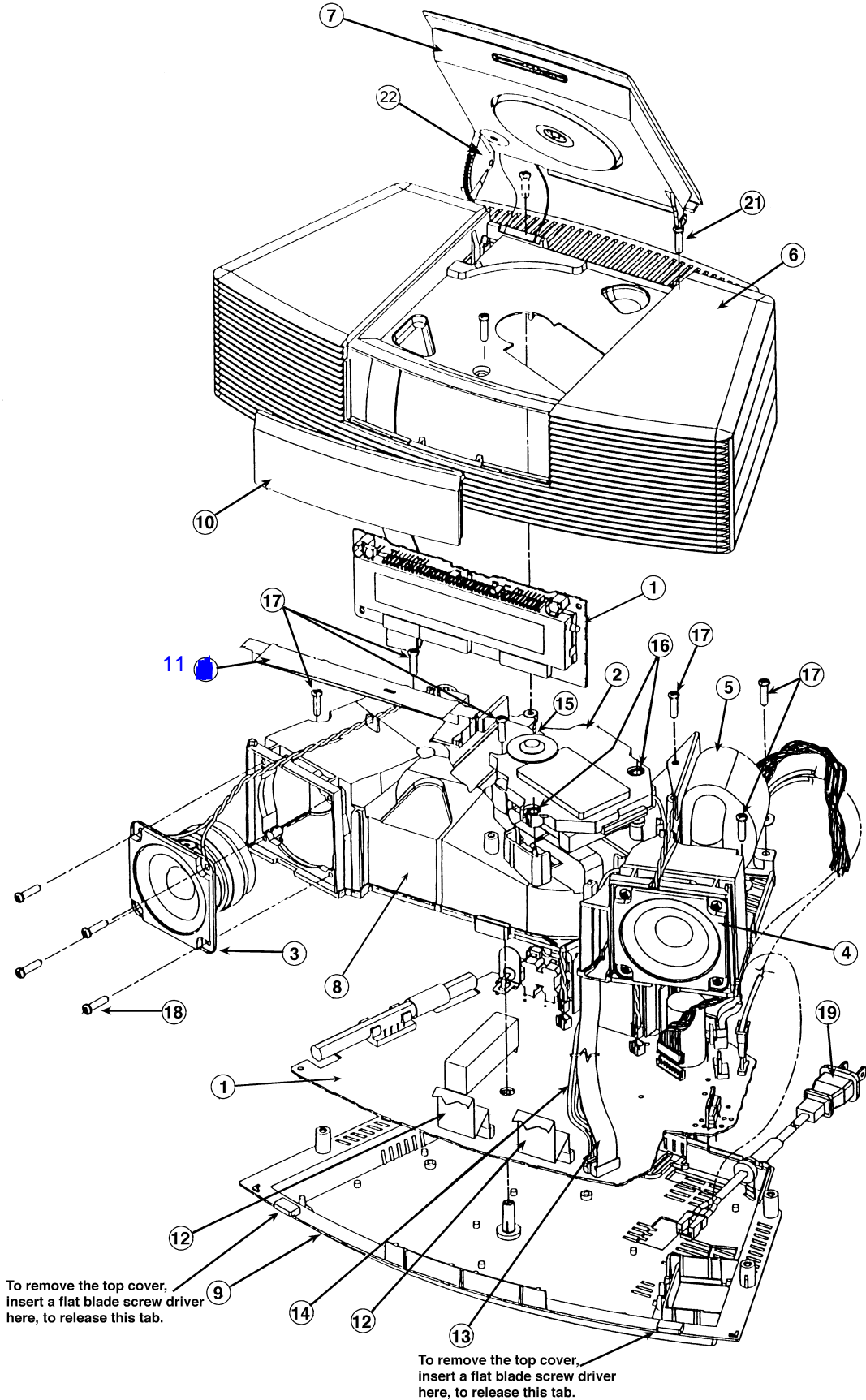







Figure 3. System Exploded View

ELECTRICAL PART LIST

Resistors

Reference Designator	Description	Part Number	Note
R1	10MEG., CF, 1/2W, 5% 	250891	3, 4 
R1	10MEG, LINE, 1/2W, 5%	250891	3, 7 
R2	POLYSWITCH, 60V	194090	
R6	10 OHM, CHIP, 0805, 5%	133626-1005	
R8	33.2K, CHIP, 0805, 1/10W, 1%	133625-3322	
R9	47.0K, 0805, 1/10W, 5%	133626-4735	
R10	47.0K, 0805, 1/10W, 5%	133626-4735	
R200	47.0K, 0805, 1/10W, 5%	133626-4735	
R201	4.7K, CHIP, 0805, 5%	133626-4725	
R202	10.0K, 0805, 1/10W, 5%	133626-1035	
R203	10.0K, 0805, 1/10W, 5%	133626-1035	
R204	4.7K, CHIP, 0805, 5%	133626-4725	
R205	47.0K, 0805, 1/10W, 5%	133626-4735	
R206	47.0K, 0805, 1/10W, 5%	133626-4735	
R207	15 OHM, FUSING, .25W	130102-150	3 
R208	330 OHM, 2512, 1W, 5%	181895-3300	
R210	10.0K, 0805, 1/10W, 5%	133626-1035	
R211	15 OHM, FUSING, .25W	130102-150	3 
R212	510 OHM, 2010, 1/2W, 5%	187608-5115	
R214	5.1 OHM, FUSING, .25W	130102-150	3 
R215	10.0K, 0805, 1/10W, 5%	133626-1035	
R220	1.00K, 0805, 1/10W, 5%	133626-1025	
R222	100K, 0805, 1/10W, 5%	133626-1045	
R223	100K, 0805, 1/10W, 5%	133626-1045	
R230	100K, 0805, 1/10W, 5%	133626-1045	
R231	10.0K, 0805, 1/10W, 1%	133625-1002	
R232	3.32K, 0805, 1/10W, 1%	133625-3321	
R300	1.00K, 0805, 1/10W, 5%	133626-1025	
R301	120 OHM, 0805, 1/10W, 1%	133625-1200	
R302	2.32K, 0805, 1/10W, 1%	133625-2321	
R303	499 OHM, CHIP, 0805, 1/10W, 1%	133625-4990	
R304	2.32K, 0805, 1/10W, 1%	133625-2321	
R305	330 OHM, 0805, 1/10W, 1%	133625-3300	
R306	51 OHM, 0805, 1/10W, 5%	133626-5105	
R307	4.7K, CHIP, 0805, 5%	133626-4725	
R308	4.99K, 0805, 1/10W, 1%	133625-4991	
R309	4.02K, 0805, 1/10W, 1%	133625-4021	
R310	47.0K, 0805, 1/10W, 5%	133626-4735	
R311	30.1 OHM, 0805, 1/10W, 1%	133625-30R1	
R313	20 OHM, 0805, 1/10W, 5%	133626-2005	

ELECTRICAL PART LIST

Resistors (continued)

Reference Designator	Description	Part Number	Note
R417	10.0K, 0805, 1/10W, 5%	133626-1035	
R418	10.0K, 0805, 1/10W, 5%	133626-1035	
R419	1.0K, ARRAY, SMT, 4 POS, 5%	186433-1024	
R420	1.0M, 0805, 1/10W, 1%	133625-1004	
R421	10.0K, 0805, 1/10W, 5%	133626-1035	
R422	100K, 0805, 1/10W, 5%	133626-1045	5, 6
R422	10.0K, 0805, 1/10W, 5%	133626-1035	4
R428	82K, CHIP, 0805, 1/10W, 5%	133626-8235	
R429	82K, CHIP, 0805, 1/10W, 5%	133626-8235	
R430	681 OHM, CHIP, 0805, 1/10W, 1%	133625-6810	
R431	82K, CHIP, 0805, 1/10W, 5%	133626-8235	
R432	82K, CHIP, 0805, 1/10W, 5%	133626-8235	
R440	220 OHM, 4 POS ARRAY, SMT, 5%	186433-2214	
R441	2.7K, 4 POS, ARRAY, SMT, 5%	186433-2724	
R442	2.7K, 4 POS, ARRAY, SMT, 5%	186433-2724	
R443	2.7K, 4 POS, ARRAY, SMT, 5%	186433-2724	
R445	10.0K, 0805, 1/10W, 5%	133626-1035	
R447	5.10K, 0805, 1/10W, 5%	133626-5125	
R448	10.0K, 0805, 1/10W, 5%	133626-1035	
R449	3.01K, 0805, 1/10W, 1%	133625-3011	
R450	1.0M, 0805, 1/10W, 1%	133625-1004	
R455	10.0K, 0805, 1/10W, 5%	133626-1035	
R460	1.0M, 0805, 1/10W, 1%	133625-1004	
R461	51 OHM, 0805, 1/10W, 5%	133626-5105	
R462	10.0K, 0805, 1/10W, 5%	133626-1035	
R463	150 OHM, CHIP, 0805, 1/10W, 1%	133625-1500	
R464	243 OHM, 0805, 1/10W, 1%	133625-2430	
R465	47 OHM, CHIP, 0805, 1/10W, 5%	133626-4705	
R466	10.0K, 0805, 1/10W, 5%	133626-1035	
R467	47.0K, 0805, 1/10W, 5%	133626-4735	
R468	681 OHM, CHIP, 0805, 1/10W, 1%	133625-6810	
R469	681 OHM, CHIP, 0805, 1/10W, 1%	133625-6810	
R470	681 OHM, CHIP, 0805, 1/10W, 1%	133625-6810	
R471	6.80K, 0805, 1/10W, 5%	133626-6825	
R472	6.80K, 0805, 1/10W, 5%	133626-6825	
R473	6.80K, 0805, 1/10W, 5%	133626-6825	
R474	6.80K, 0805, 1/10W, 5%	133626-6825	
R475	16.5K, CHIP, 0805, 1%	133625-1652	
R476	16.5K, CHIP, 0805, 1%	133625-1652	
R477	1.00K, 0805, 1/10W, 5%	133626-1025	
R480	2.7K, 4 POS, ARRAY, SMT, 5%	186433-2724	
R485	10.0K, 0805, 1/10W, 5%	133626-1035	
R490	510 OHM, 0805, 1/10W, 5%	133626-5115	
R491	510 OHM, 0805, 1/10W, 5%	133626-5115	

ELECTRICAL PART LIST

Resistors (continued)

Reference Designator	Description	Part Number	Note
R495	JUMPER, CHIP, 0805	133627	
R500	1.00K, 0805, 1/10W, 5%	133626-1025	
R501	499 OHM, CHIP, 0805, 1/10W, 1%	133625-4990	
R503	13.3K, 0805, 1/10W, 1%	133625-1332	
R504	27.4K, CHIP, 0805, 1/10W, 1%	133625-2742	
R505	562 OHM, 0805, 1/10W, 1%	133625-5620	
R506	1.00K, 0805, 1/10W, 5%	133626-1025	
R507	100K, 0805, 1/10W, 1%	133625-1003	
R508	68.1K, 0805, 1/10W, 1%	133625-6812	
R509	15.0K, 0805, 1/10W, 1%	133625-1502	
R510	3.32K, 0805, 1/10W, 1%	133625-3321	
R513	1 OHM, 0805, 1/10W, 5%	133626-1R05	
R514	8.25K, CHIP, 0805, 1/10W, 1%	133625-8251	
R515	2.21K, CHIP, 0805, 1/10W, 1%	133625-2211	
R516	221K, 0805, 1/10W, 1%	133625-2213	
R519	15.0K, 0805, 1/10W, 1%	133625-1502	
R520	22.1K, 0805, 1/10W, 1%	133625-2212	
R521	7.50K, 0805, 1/10W, 1%	133625-7501	
R522	7.50K, 0805, 1/10W, 1%	133625-7501	
R527	1 OHM, 0805, 1/10W, 5%	133626-1R05	
R528	12.7K, 0805, 1/10W, 1%	133625-1272	
R529	33.2K, CHIP, 0805, 1/10W, 1%	133625-3322	
R530	20.0K, CHIP, 0805, 1/10W, 1%	133625-2002	
R531	2.21K, CHIP, 0805, 1/10W, 1%	133625-2211	10
R531	2.74K, 0805, 1/10W, 1%	133625-2741	9
R532	56.2K, CHIP, 0805, 1%,	133625-5622	
R533	1.82K, 0805, 1/10W, 1%	133625-1821	
R534	56.2K, CHIP, 0805, 1%	133625-5622	
R535	221K, 0805, 1/10W, 1%	133625-2213	
R536	221K, 0805, 1/10W, 1%	133625-2213	
R537	15.0K, 0805, 1/10W, 1%	133625-1502	
R538	22.1K, 0805, 1/10W, 1%	133625-2212	
R539	270K, 0805, 1/10W, 5%	133626-2745	
R540	332 OHM, CHIP, 0805, 1%	133625-3320	
R543	10.0K, 0805, 1/10W, 1%	133625-1002	
R544	47.5K, CHIP, 0805, 1/10W, 1%	133625-4752	
R545	33.2K, CHIP, 0805, 1/10W, 1%	133625-3322	
R546	22.1K, 0805, 1/10W, 1%	133625-2212	
R547	12.1K, 0805, 1/10W, 1%	133625-1212	
R548	1.00K, CHIP, 0805, 1/10W, 1%	133625-1001	
R549	15.0K, 0805, 1/10W, 1%	133625-1502	
R550	332 OHM, CHIP, 0805, 1%	133625-3320	
R551	1.21K, 0805, 1/10W, 1%	133625-1211	
R552	681 OHM, CHIP, 0805, 1/10W, 1%	133625-6810	

ELECTRICAL PART LIST

Resistors (continued)

Reference Designator	Description	Part Number	Note
R553	68.1K, 0805, 1/10W, 1%	133625-6812	
R554	1.00K, 0805, 1/10W, 5%	133626-1025	
R555	7.50K, 0805, 1/10W, 1%	133625-7501	10
R555	15K, CHIP, 0805, 1/10W, 5%	133626-1535	9
R556	15.0K, 0805, 1/10W, 1%	133625-1502	
R557	1 OHM, 0805, 1/10W, 5%	133626-1R05	
R558	20 OHM, 0805, 1/10W, 5%	133626-2005	
R559	47.0K, 0805, 1/10W, 5%	133626-4735	
R560	15.0K, 0805, 1/10W, 1%	133625-1502	
R561	1.00K, 0805, 1/10W, 5%	133626-1025	
R562	27.4K, CHIP, 0805, 1/10W, 1%	133625-2742	
R565	10 OHM, CHIP, 0805, 5%	133626-1005	
R566	1.00K, 0805, 1/10W, 5%	133626-1025	
R568	47.0K, 0805, 1/10W, 5%	133626-4735	
R569	2.21K, CHIP, 0805, 1/10W, 1%	133625-2211	
R570	2.21K, CHIP, 0805, 1/10W, 1%	133625-2211	
R571	7.50K, 0805, 1/10W, 1%	133625-7501	
R571	JUMPER, CHIP, 0805	133627	
R572	221K, 0805, 1/10W, 1%	133625-2213	
R573	221K, 0805, 1/10W, 1%	133625-2213	
R574	1.00K, 0805, 1/10W, 5%	133626-1025	
R575	1.00K, 0805, 1/10W, 5%	133626-1025	
R580	10.0K, 0805, 1/10W, 5%	133626-1035	
R600	10.0K, 0805, 1/10W, 1%	133625-1002	
R601	10.0K, 0805, 1/10W, 1%	133625-1002	
R603	1.10K, 0805, 1/10W, 1%	133625-1101	
R604	14.7K, CHIP, 0805, 1%	133625-1472	
R605	1.10K, 0805, 1/10W, 1%	133625-1101	
R606	14.7K, CHIP, 0805, 1%	133625-1472	
R607	5.62K, CHIP, 0805, 1/10W, 1%	133625-5621	
R608	12.7K, 0805, 1/10W, 1%	133625-1272	
R609	35.7K, 0805, 1/10W, 1%	133625-3572	
R610	4.02K, 0805, 1/10W, 1%	133625-4021	
R611	3.48K, 0805, 1/10W, 1%	133625-3481	
R612	10.0K, 0805, 1/10W, 1%	133625-1002	
R613	1.87K, 0805, 1/10W, 1%	133625-1871	
R615	14.0K, CHIP, 0805, 1%	133625-1402	
R616	6.81K, CHIP, 0805, 1/10W, 1%	133625-6811	
R617	6.81K, CHIP, 0805, 1/10W, 1%	133625-6811	
R618	1.40K, 0805, 1/10W, 1%	133625-1401	
R619	10.5K, 0805, 1/10W, 1%	133625-1052	
R620	11.3K, 0805, 1/10W, 1%	133625-1132	
R621	3.74K, 0805, 1/10W, 1%	133625-3741	
R622	30.1K, CHIP, 0805, 1/10W, 1%	133625-3012	

ELECTRICAL PART LIST

Resistors (continued)

Reference Designator	Description	Part Number	Note
R623	4.75K, 0805, 1/10W, 1%	133625-4751	
R624	1.27K, 0805, 1/10W, 1%	133625-1271	
R625	14.0K, CHIP, 0805, 1%	133625-1402	
R626	41.2K, 0805, 1/10W, 1%	133625-4122	
R627	715 OHM, 0805, 1/10W, 1%	133625-7150	
R628	2.10K, 0805, 1/10W, 1%	133625-2101	
R629	3.74K, 0805, 1/10W, 1%	133625-3741	
R630	8.87K, 0805, 1/10W, 1%	133625-8871	
R631	8.87K, 0805, 1/10W, 1%	133625-8871	
R632	1.10K, 0805, 1/10W, 1%	133625-1101	
R633	26.7K, 0805, 1/10W, 1%	133625-2672	
R634	787 OHM, 0805, 1/10W, 1%	133625-7870	
R635	25.5K, 0805, 1/10W, 1%	133625-2552	
R636	2.00K, 0805, 1/10W, 1%	133625-2001	
R637	221K, 0805, 1/10W, 1%	133625-2213	
R638	25.5K, 0805, 1/10W, 1%	133625-2552	
R639	475 OHM, 0805, 1/10W, 1%	133625-4750	
R640	10.2K, CHIP, 0805, 1/10W, 1%	133625-1022	
R642	15.0K, 0805, 1/10W, 1%	133625-1502	
R643	8.2K, CHIP, 0805, 1/10W, 5%	133626-8225	
R645	4.22K, 0805, 1/10W, 1%	133625-4221	
R647	1.00K, 0805, 1/10W, 5%	133626-1025	
R649	100K, 0805, 1/10W, 5%	133626-1045	
R650	1.00K, 0805, 1/10W, 5%	133626-1025	
R651	100K, 0805, 1/10W, 5%	133626-1045	
R655	75.0K, 0805, 1/10W, 1%	133625-7502	
R656	4.99K, 0805, 1/10W, 1%	133625-4991	
R657	75.0K, 0805, 1/10W, 1%	133625-7502	
R659	1.00K, 0805, 1/10W, 5%	133626-1025	
R660	4.99K, 0805, 1/10W, 1%	133625-4991	
R662	1.00K, 0805, 1/10W, 5%	133626-1025	
R663	150K, 0805, 1/10W, 1%	133625-1503	
R664	1.00K, 0805, 1/10W, 5%	133626-1025	
R665	1.00K, 0805, 1/10W, 5%	133626-1025	
R666	1.00K, 0805, 1/10W, 5%	133626-1025	
R667	1.00K, CHIP, 0805, 1/10W, 1%	133625-1001	
R668	100K, 0805, 1/10W, 1%	133625-1003	
R669	100K, 0805, 1/10W, 1%	133625-1003	
R670	10.0K, 0805, 1/10W, 5%	133626-1035	
R672	1.00K, CHIP, 0805, 1/10W, 1%	133625-1001	
R674	1.78K, 0805, 1/10W, 1%	133625-1781	

ELECTRICAL PART LIST

Capacitors

Reference Designator	Description	Part Number	Note
C1	33pF, CER, 85, 400VAC, 20%	183627-330	3, 4, 7 
C2	.1uF, 1206, X7R, 25V, 5%	131754-104	
C3	.1uF, 1206, X7R, 25V, 5%	131754-104	
C4	.1uF, 1206, X7R, 25V, 5%	131754-104	
C5	.1uF, 1206, X7R, 25V, 5%	131754-104	
C6	10kuF, EL, 105, 25V, 20%	171555	
C7	.22uF, BOX, 85, 50V, 5%	137127-224	
C8	.47uF, BOX, 85, 50V, 5%	137127-474	
C9	220pF, 0805, COG, 50V, 5%	133622-221	
C10	220pF, 0805, COG, 50V, 5%	133622-221	
C11	.01uF, 0805, X7R, 50V, 10%	133623-103	
C12	100uF, EL, 85, 16V, 20%	149947-101C	
C13	.001uF, 1206, COG, 50V, 5%	177214-102	
C15	.10uF, 0805, Y5V, 25V, 80%	133624	
C16	2200uF, EL, 105C, 16V, 20%	198458-222C	
C20	.047uF, 0805, X7R, 50V, 10%	133623-473	
C200	.047uF, 0805, X7R, 50V, 10%	133623-473	
C201	.047uF, 0805, X7R, 50V, 10%	133623-473	
C202	470uF, EL, 105, 35V, 20%	144000-471V	
C203	.047uF, 0805, X7R, 50V, 10%	133623-473	
C205	470UF, EL, 105, 35V, 20%	144000-471V	
C209	.047uF, 0805, X7R, 50V, 10%	133623-473	
C210	.047uF, 0805, X7R, 50V, 10%	133623-473	
C211	330pF, 0805, COG, 50V, 5%	133622-331	
C215	.047uF, 0805, X7R, 50V, 10%	133623-473	
C216	.047uF, 0805, X7R, 50V, 10%	133623-473	
C217	.10uF, 0805, Y5V, 25V, 80%	133624	
C218	10uF, EL, 105, 16V, 20%	137126-100	
C219	.10uF, 0805, Y5V, 25V, 80%	133624	
C220	2.2uF, EL, 85, 50V, 20%	149947-2R2H	
C221	100pF, 0805, COG, 50V, 5%	133622-101	
C225	.047uF, 0805, X7R, 50V, 10%	133623-473	
C226	330pF, 0805, COG, 50V, 5%	133622-331	
C227	330pF, 0805, COG, 50V, 5%	133622-331	
C229	2.2uF, EL, 85, 50V, 20%	149948-2R2H	
C231	.047uF, 0805, X7R, 50V, 10%	133623-473	
C232	.047uF, 0805, X7R, 50V, 10%	133623-473	
C233	1uF, 1206, Y5V, 16V, 80%	173383-105	
C300	1000pF, 0805, COG, 50V, 5%	133622-102	
C301	.047uF, 0805, X7R, 50V, 10%	133623-473	
C302	47uF, EL, 85, 16V, 20%	149947-470C	
C303	.047uF, 0805, X7R, 50V, 10%	133623-473	

ELECTRICAL PART LIST

Capacitors (continued)

Reference Designator	Description	Part Number	Note
C304	6.8pF, CHIP, 0805, 50V, 5%	133622-6R8	
C305	.047uF, 0805, X7R, 50V, 10%	133623-473	
C307	20pF, TRIM, NPO, 100V	197314-T200	
C308	430pF, 0805, COG, 50V, 2%	177269-431	
C309	47uF, EL, 85, 25V, 20%	149948-470E	
C310	.047uF, 0805, Z5U, 20%	148779-473	
C311	3.3uF, EL, 85, 50V, 20%	149948-3R3H	
C312	.047uF, 0805, Z5U, 20%	148779-473	
C313	47uF, EL, 85, 25V, 20%	149948-470E	
C314	2.2UF, MONO, 1206, Y5V, 16V, 80%	178212-225	
C315	.01uF, 0805, X7R, 50V, 10%	133623-103	
C316	.047uF, 0805, Z5U, 20%	148779-473	
C317	47uF, EL, 85, 25V, 20%	149948-470E	
C318	2.2uF, EL, 85, 50V, 20%	149948-2R2H	
C319	.047uF, 0805, Z5U, 20%	148779-473	
C320	1.0uF, EL, 85, 50V, 20%	149948-1R0H	
C321	.47uF, EL, 85, 50V, 20%	149948-R47H	
C323	1.0uF, EL, 85, 50V, 20%	149948-1R0H	
C325	10uF, EL, 85, 25V, 20%	149948-100E	
C328	1.0uF, EL, BP, 85, 50V, 20%	147522-1R0	
C329	10uF, EL, 85, 25V, 20%	149948-100E	
C330	.047uF, 0805, X7R, 50V, 10%	133623-473	4
C330	.033uF, 0805, X7R, 50V, 10%	133623-333	5, 6, 7
C331	.047uF, 0805, X7R, 50V, 10%	133623-473	4
C331	.033uF, 0805, X7R, 50V, 10%	133623-333	5, 6, 7
C332	1000pF, 0805, COG, 50V, 5%	133622-102	
C333	1.0uF, EL, 85, 50V, 20%	149948-1R0H	
C335	2.2uF, EL, BP, 85, 50V, 20%	147522-2R2	
C336	.01uF, 0805, X7R, 50V, 10%	133623-103	
C337	1000pF, 0805, COG, 50V, 5%	133622-102	
C338	1000pF, 0805, COG, 50V, 5%	133622-102	
C339	1000pF, 0805, COG, 50V, 5%	133622-102	
C340	3300pF, 0805, X7R, 50V, 10%	133623-332	
C341	27pF, 0805, COG, 50V, 5%	133622-270	10
C341	39pF, 0805, COG, 50V, 5%	133622-390	9
C342	27pF, 0805, COG, 50V, 5%	133622-270	10
C342	39pF, 0805, COG, 50V, 5%	133622-390	9
C343	.047uF, 0805, X7R, 50V, 10%	133623-473	
C344	100UF, EL, BP, 85, 16V, 20%	147522-101	
C345	.047uF, 0805, X7R, 50V, 10%	133623-473	
C348	1000pF, 0805, COG, 50V, 5%	133622-102	
C349	1000pF, 0805, COG, 50V, 5%	133622-102	
C355	1000pF, 0805, COG, 50V, 5%	133622-102	
C356	100pF, 0805, COG, 50V, 5%	133622-101	

ELECTRICAL PART LIST

Capacitors (continued)

Reference Designator	Description	Part Number	Note
C357	100pF, 0805, COG, 50V, 5%	133622-101	
C358	10uF, EL, 85, 25V, 20%	149947-100E	
C359	4.7uF, EL, 85, 50V, 20%	149947-4R7H	
C360	330pF, 0805, COG, 50V, 5%	133622-331	
C365	1.0uF, EL, 85, 50V, 20%	149948-1R0H	
C366	1.0uF, EL, 85, 50V, 20%	149948-1R0H	
C367	1800pF, 0805, COG, 50V, 5%	133622-182	
C368	1800pF, 0805, COG, 50V, 5%	133622-182	
C371	330pF, 0805, COG, 50V, 5%	133622-331	
C375	330pF, 0805, COG, 50V, 5%	133622-331	
C376	330pF, 0805, COG, 50V, 5%	133622-331	
C377	1000pF, 0805, COG, 50V, 5%	133622-102	
C378	.10uF, 0805, Y5V, 25V, 80%	133624	
C380	330pF, 0805, COG, 50V, 5%	133622-331	
C381	330pF, 0805, COG, 50V, 5%	133622-331	
C382	1000pF, 0805, COG, 50V, 5%	133622-102	
C384	100pF, 0805, COG, 50V, 5%	133622-101	
C385	100pF, 0805, COG, 50V, 5%	133622-101	
C386	100pF, 0805, COG, 50V, 5%	133622-101	
C387	1000pF, 0805, COG, 50V, 5%	133622-102	
C388	33pF, 0805, COG, 50V, 5%	133622-330	
C400	330pF, 0805, COG, 50V, 5%	133622-331	
C401	330pF, 0805, COG, 50V, 5%	133622-331	
C402	330pF, 0805, COG, 50V, 5%	133622-331	
C403	330pF, 0805, COG, 50V, 5%	133622-331	
C404	330pF, 0805, COG, 50V, 5%	133622-331	
C405	330pF, 0805, COG, 50V, 5%	133622-331	
C406	3300pF, 0805, X7R, 50V, 10%	133623-332	
C407	3300pF, 0805, X7R, 50V, 10%	133623-332	
C408	3300pF, 0805, X7R, 50V, 10%	133623-332	
C409	3300pF, 0805, X7R, 50V, 10%	133623-332	
C410	3300pF, 0805, X7R, 50V, 10%	133623-332	
C411	3300pF, 0805, X7R, 50V, 10%	133623-332	
C412	.047uF, 0805, Z5U, 20%	148779-473	
C413	330pF, 0805, COG, 50V, 5%	133622-331	
C414	330pF, 0805, COG, 50V, 5%	133622-331	
C415	1000pF, 0805, COG, 50V, 5%	133622-102	
C416	330pF, 0805, COG, 50V, 5%	133622-331	
C417	.01uF, 0805, X7R, 50V, 10%	133623-103	
C418	100pF, 0805, COG, 50V, 5%	133622-101	
C419	1000pF, 0805, COG, 50V, 5%	133622-102	
C422	100pF, 0805, COG, 50V, 5%	133622-101	
C423	100pF, 0805, COG, 50V, 5%	133622-101	
C424	100pF, 0805, COG, 50V, 5%	133622-101	

ELECTRICAL PART LIST

Capacitors (continued)

Reference Designator	Description	Part Number	Note
C425	1000pF, 0805, COG, 50V, 5%	133622-102	
C426	2.2uF, MONO, 1206, Y5V, 16V, 80%	178212-225	
C434	47pF, 0805, COG, 50V, 5%	133622-470	
C435	47pF, 0805, COG, 50V, 5%	133622-470	
C436	47pF, 0805, COG, 50V, 5%	133622-470	
C437	47pF, 0805, COG, 50V, 5%	133622-470	
C438	1.0uF, 1206, Y5V, 25V, 80%	198609-105	
C439	1.0uF, 1206, Y5V, 25V, 80%	198609-105	
C440	15uF, TANT, 25V, 10%, D SIZE	196981- E156D1	
C441	180pF, 0805, COG, 50V, 5%	133622-181	
C442	820pF, 0805, COG, 50V, 5%	133622-821	
C443	820pF, 0805, COG, 50V, 5%	133622-821	
C444	820pF, 0805, COG, 50V, 5%	133622-821	
C445	2200pF, 0805, X7R, 50V, 10%	133623-222	
C446	820pF, 0805, COG, 50V, 5%	133622-821	
C447	820pF, 0805, COG, 50V, 5%	133622-821	
C448	820pF, 0805, COG, 50V, 5%	133622-821	
C449	820pF, 0805, COG, 50V, 5%	133622-821	
C450	820pF, 0805, COG, 50V, 5%	133622-821	
C451	820pF, 0805, COG, 50V, 5%	133622-821	
C452	180pF, 0805, COG, 50V, 5%	133622-181	
C453	820pF, 0805, COG, 50V, 5%	133622-821	
C454	820pF, 0805, COG, 50V, 5%	133622-821	
C455	820pF, 0805, COG, 50V, 5%	133622-821	
C456	4700pF, 0805, X7R, 50V, 10%	133623-472	
C457	820pF, 0805, COG, 50V, 5%	133622-821	
C458	820pF, 0805, COG, 50V, 5%	133622-821	
C459	820pF, 0805, COG, 50V, 5%	133622-821	
C460	820pF, 0805, COG, 50V, 5%	133622-821	
C461	.1uF, 1206, X7R, 25V, 5%	131754-104	
C462	330pF, 0805, COG, 50V, 5%	133622-331	
C463	330pF, 0805, COG, 50V, 5%	133622-331	
C464	330pF, 0805, COG, 50V, 5%	133622-331	
C465	.01uF, 0805, X7R, 50V, 10%	133623-103	
C466	.10uF, 0805, Y5V, 25V, 80%	133624	
C467	15uF, TANT, 25V, 10%, D SIZE	196981- E156D1	
C468	1uF, 1206, Y5V, 16V, 80%	173383-105	
C469	330pF, 0805, COG, 50V, 5%	133622-331	
C470	100pF, 0805, COG, 50V, 5%	133622-101	
C471	100pF, 0805, COG, 50V, 5%	133622-101	
C472	1000pF, 0805, COG, 50V, 5%	133622-102	
C473	1000pF, 0805, COG, 50V, 5%	133622-102	

ELECTRICAL PART LIST

Capacitors (continued)

Reference Designator	Description	Part Number	Note
C474	1000pF, 0805, COG, 50V, 5%	133622-102	
C475	.01uF, 0805, X7R, 50V, 10%	133623-103	
C476	1000pF, 0805, COG, 50V, 5%	133622-102	
C477	1000pF, 0805, COG, 50V, 5%	133622-102	
C478	330pF, 0805, COG, 50V, 5%	133622-331	
C479	330pF, 0805, COG, 50V, 5%	133622-331	
C480	330pF, 0805, COG, 50V, 5%	133622-331	
C481	330pF, 0805, COG, 50V, 5%	133622-331	
C482	330pF, 0805, COG, 50V, 5%	133622-331	
C483	330pF, 0805, COG, 50V, 5%	133622-331	
C485	330pF, 0805, COG, 50V, 5%	133622-331	
C490	4700pF, 0805, X7R, 50V, 10%	133623-472	
C491	4700pF, 0805, X7R, 50V, 10%	133623-472	
C492	4700pF, 0805, X7R, 50V, 10%	133623-472	
C493	1000pF, 0805, COG, 50V, 5%	133622-102	
C494	1000pF, 0805, COG, 50V, 5%	133622-102	
C495	1000pF, 0805, COG, 50V, 5%	133622-102	
C502	10uF, EL, 85, 25V, 20%	149947-100E	
C503	.22uF, BOX, 85, 50V, 5%	137127-224	
C504	330pF, 0805, COG, 50V, 5%	133622-331	
C505	.015uF, BOX, 85, 100V, 5%	137127-153	
C506	.033uF, BOX, 85, 63V, 5%	137127-333	
C507	.033uF, BOX, 85, 63V, 5%	137127-333	
C508	.0068uF, BOX, 85, 100V, 5%	137127-682	
C509	.15uF, BOX, 85, 50V, 5%	137127-154	
C510	220uF, EL, 85, 6.3V, 20%	149947-221J	
C511	.01uF, 0805, X7R, 50V, 10%	133623-103	
C512	.15uF, BOX, 85, 50V, 5%	137127-154	
C513	.033uF, BOX, 85, 63V, 5%	137127-333	
C514	.01uF, BOX, 85, 100V, 5%	137127-103	
C519	.022uF, 0805, X7R, 50V, 10%	133623-223	
C520	100uF, EL, 85, 16V, 20%	149947-101C	
C521	100uF, EL, 85, 16V, 20%	149947-101C	
C522	.01uF, 0805, X7R, 50V, 10%	133623-103	
C523	10uF, EL, 85, 25V, 20%	149947-100E	
C524	1.0uF, EL, 85, 50V, 20%	149947-1R0H	
C525	.15uF, BOX, 85, 50V, 5%	137127-154	
C526	.15uF, BOX, 85, 50V, 5%	137127-154	
C527	.01uF, BOX, 85, 100V, 5%	137127-103	
C528	220pF, 0805, COG, 50V, 5%	133622-221	
C529	.0033uF, BOX, 85, 100V, 5%	137127-332	
C530	.01uF, BOX, 85, 100V, 5%	137127-103	
C531	10uF, EL, 85, 25V, 20%	149947-100E	
C532	47uF, EL, 85, 16V, 20%	149947-470C	

ELECTRICAL PART LIST

Capacitors (continued)

Reference Designator	Description	Part Number	Note
C533	.47uF, EL, BP, 85, 50V, 20%	147522-R47	
C534	4.7uF, EL, 85, 50V, 20%	149947-4R7H	
C535	.33uF, BOX, 85, 50V, 5%	137127-334	
C536	.1uF, BOX, 85, 50V, 5%	137127-104	
C537	.01uF, BOX, 85, 100V, 5%	137127-103	
C538	.001uF, BOX, 85, 100V, 5%	137127-102	
C539	3.9pF, 0805, COG, 50V, 5%	133622-3R9	
C540	100pF, 0805, COG, 50V, 5%	133622-101	
C541	12pF, 0805, COG, 50V, 5%	133622-120	
C542	.01uF, BOX, 85, 100V, 5%	137127-103	
C543	.1uF, BOX, 85, 50V, 5%	137127-104	
C544	.1uF, BOX, 85, 50V, 5%	137127-104	
C545	.10uF, 0805, Y5V, 25V, 80%	133624	
C546	100pF, 0805, COG, 50V, 5%	133622-101	
C547	10pF, 0805, COG, 50V, 5%	133622-100	
C548	10pF, 0805, COG, 50V, 5%	133622-100	
C549	.10uF, 0805, Y5V, 25V, 80%	133624	
C550	100uF, EL, 85, 16V, 20%	149947-101C	
C551	.10uF, 0805, Y5V, 25V, 80%	133624	
C552	47uF, EL, 85, 16V, 20%	149947-470C	
C553	.10uF, 0805, Y5V, 25V, 80%	133624	
C554	.01uF, 0805, X7R, 50V, 10%	133623-103	
C555	4.7uF, EL, 85, 50V, 20%	149947-4R7H	
C556	4.7uF, EL, 85, 50V, 20%	149947-4R7H	
C557	.10uF, 0805, Y5V, 25V, 80%	133624	
C558	1.0uF, EL, 85, 50V, 20%	149947-1R0H	
C559	.047uF, 0805, X7R, 50V, 10%	133623-473	
C560	1000pF, 0805, COG, 50V, 5%	133622-102	
C561	.047uF, 0805, Z5U, 20%	148779-473	
C562	1000pF, 0805, COG, 50V, 5%	133622-102	
C563	220pF, 0805, COG, 50V, 5%	133622-221	
C570	330pF, 0805, COG, 50V, 5%	133622-331	
C571	330pF, 0805, COG, 50V, 5%	133622-331	
C572	1000pF, 0805, COG, 50V, 5%	133622-102	
C600	.1uF, BOX, 85, 50V, 5%	137127-104	
C601	.027uF, BOX, 85, 63V, 5%	137127-273	
C602	.01uF, BOX, 85, 100V, 5%	137127-103	
C603	.01uF, BOX, 85, 100V, 5%	137127-103	
C605	.18uF, BOX, 85, 50V, 5%	137127-184	
C606	.18uF, BOX, 85, 50V, 5%	137127-184	
C607	.33uF, BOX, 85, 50V, 5%	137127-334	
C608	.33uF, BOX, 85, 50V, 5%	137127-334	
C609	.0047uF, BOX, 85, 100V, 5%	137127-472	
C610	820pF, 0805, COG, 50V, 5%	133622-821	

ELECTRICAL PART LIST

Capacitors (continued)

Reference Designator	Description	Part Number	Note
C611	.033uF, BOX, 85, 63V, 5%	137127-333	
C612	.033uF, BOX, 85, 63V, 5%	137127-333	
C613	.0056uF, BOX, 85, 100V, 5%	137127-562	
C614	.01uF, BOX, 85, 100V, 5%	137127-103	
C615	.01uF, BOX, 85, 100V, 5%	137127-103	
C616	.1uF, BOX, 85, 50V, 5%	137127-104	
C617	.1uF, BOX, 85, 50V, 5%	137127-104	
C618	.0022uF, BOX, 85, 100V, 5%	137127-222	
C619	820pF, 0805, COG, 50V, 5%	133622-821	
C620	.47uF, BOX, 85, 50V, 5%	137127-474	
C621	.47uF, BOX, 85, 50V, 5%	137127-474	
C622	.047uF, BOX, 85, 63V, 5%	137127-473	
C623	.047uF, BOX, 85, 63V, 5%	137127-473	
C624	10uF, EL, 85, 25V, 20%	149947-100E	
C627	.1uF, 1206, X7R, 25V, 5%	131754-104	
C628	.1uF, 1206, X7R, 25V, 5%	131754-104	
C629	.1uF, 1206, X7R, 25V, 5%	131754-104	
C630	2.2uF, EL, 85, 50V, 20%	149947-2R2H	
C631	2.2uF, EL, 85, 50V, 20%	149947-2R2H	
C634	100pF, 0805, COG, 50V, 5%	133622-101	
C635	100pF, 0805, COG, 50V, 5%	133622-101	
C636	2.2uF, EL, 85, 50V, 20%	149947-2R2H	
C637	2.2uF, EL, 85, 50V, 20%	149947-2R2H	
C639	1000pF, 0805, COG, 50V, 5%	133622-102	
C640	100pF, 0805, COG, 50V, 5%	133622-101	
C641	100pF, 0805, COG, 50V, 5%	133622-101	
C642	22uF, EL, 85, 16V, 20%	149947-220C	
C645	.18uF, BOX, 85, 50V, 5%	137127-184	
C646	.18uF, BOX, 85, 50V, 5%	137127-184	
C647	4.7uF, EL, 85, 50V, 20%	149947-4R7H	
C650	2.2UF, EL, 85, 50V, 20%	149947-2R2H	
C651	1000pF, 0805, COG, 50V, 5%	133622-102	
C652	1000pF, 0805, COG, 50V, 5%	133622-102	
C655	100pF, 0805, COG, 50V, 5%	133622-101	
C656	100pF, 0805, COG, 50V, 5%	133622-101	
C657	100pF, 0805, COG, 50V, 5%	133622-101	
C658	100pF, 0805, COG, 50V, 5%	133622-101	
C665	.18uF, BOX, 85, 50V, 5%	137127-184	
C666	.18uF, BOX, 85, 50V, 5%	137127-184	
C667	2.2uF, EL, BP, 85, 50V, 20%	147522-2R2	
C681	2.2uF, EL, BP, 85, 50V, 20%	147522-2R2	
C682	100pF, 0805, COG, 50V, 5%	133622-101	
C683	100pF, 0805, COG, 50V, 5%	133622-101	
C684	100pF, 0805, COG, 50V, 5%	133622-101	

ELECTRICAL PART LIST

Capacitors (continued)

Reference Designator	Description	Part Number	Note
C685	100pF, 0805, COG, 50V, 5%	133622-101	
C686	470uF, EL, 85, 16V, 20%	149948-471C	
C687	.01uF, 0805, X7R, 50V, 10%	133623-103	
C688	.01uF, 0805, X7R, 50V, 10%	133623-103	
C689	.1uF, 0805, X7R, 50V, 10%	133623-103	

Diodes

Reference Designator	Description	Part Number	Note
D1	BAV99, DUAL, SOT-23	147239	
D3	DUAL, SOT-23, COMMON NEG	250682	
D200	SMT, S1G	178380-4	
D201	SMT, S1G	178380-4	
D202	DUAL, SOT-23, COMMON NEG	250682	
D203	DIODE, SHOTTKY, BAT42W, SOD-123	196984-002	
D204	BAV99, DUAL, SOT-23	147239	
D206	BAV99, DUAL, SOT-23	147239	
D207	DUAL, SOT-23, COMMON NEG	250682	
D211	DUAL, SOT-23, COMMON NEG	250682	
D212	BAV99, DUAL, SOT-23	147239	
D213	BAV99, DUAL, SOT-23	147239	
D300	BAV99, DUAL, SOT-23	147239	
D302	BAV99, DUAL, SOT-23	147239	
D304	DIODE, VARACTOR, DUAL, 20V, 50mA	177495-5	
D305	BAV99, DUAL, SOT-23	147239	
D401	SENSOR, LIGHT, VISIBLE	187629-001	
D600	DUAL, SOT-23, COMMON NEG	250682	
ZR200	1N5232, ZENER, 5.6V, 225MW	135247-5232	
BR1	KBJ601G, RECTIFIER, BRIDGE	187611-001	3

Transistors

Reference Designator	Description	Part Number	Note
Q4	SOT23, BPLR, P, 40V, 200mA	148596	
Q200	SOT23, BPLR, N, 50V, 100mA	146817	
Q201	TO-92, BPLR, P, 60V, 200mA	119168	
Q202	TO-92, BPLR, P, 60V, 200mA	119168	
Q206	TO-92, BPLR, P, 60V, 200mA	119168	
Q207	SOT23, BPLR, N, 4.7K	192603	
Q208	TO-92, BPLR, P, 60V, 200mA	119168	

ELECTRICAL PART LIST

Transistors (continued)

Reference Designator	Description	Part Number	Note
Q209	SOT23, BPLR, N, 50V, 100mA	146817	
Q210	SOT23, BPLR, P, 40V, 200mA	148596	
Q211	BPLR, P, SOT, HI-HFE	252042	
Q212	MOSFET, N, SOT	252043	
Q300	2SA1341, P, 50V	146818	
Q301	SOT23, BPLR, N, 50V, 100mA	146817	
Q303	SOT-23, BPLR, N, 25V, 30mA	187601-001	
Q304	SOT23, BPLR, N, 55V, 150mA	134741	
Q400	2SA1341, P, 50V	146818	
Q401	SENSOR, IR DETECTING	182493-38	
Q402	2SA1341, P, 50V	146818	
Q403	2SA1341, P, 50V	146818	
Q404	2SA1341, P, 50V	146818	
Q405	SOT-23, NPN, HIHfe	250681	
Q406	SOT-23, NPN, HIHfe	250681	
Q500	SOT23, BPLR, P, 40V, 200mA	148596	
Q501	2SD8790V, TO-92, N	193457	
Q600	2SA1341, P, 50V	146818	
Q602	2SA1341, P, 50V	146818	
Q603	SOT23, BPLR, N, 50V, 100mA	146817	

Integrated Circuits



Reference Designator	Description	Part Number	Note
U1	TDA7375A, POWER AMP, MW15	250117	
U200	VOLT REG, 15V, NEG, TO-92	193423-15	
U201	LM78M10, T220	178352-10	
U202	VOLT REG, POS, 5V, LO-VD/IQ	193401-05R0	
U203	LM78M05, T220	178352-05	
U300	AM/FM TUNER, SO-20LA1836	187600-001	
U301	PLL FREQ SYNTH, MFP-24	199693	10
U301	LC72131, PLL FREQ SYNTH, MFP-20	187733-001	9
U400	UC, MASKED, REV3.8	253545-03R6	
U401	EEPROM, 1K, 24C01A	184044	
U403	RESET, SOT23, MAX809, 4.63V	191158-01	
U500	LA9241M, CD ASP, QFP64	187721-001	
U501	LC78622E, CD DSP, QFP64	187722-001	
U502	LA6541D, MTR DRIVER, DIP30	193432	
U600	TLO74D, QUAD OPAMP, SOIC	186112	
U601	TLO74D, QUAD OPAMP, SOIC	186112	
U603	NJM13700, TRANS, DUAL, SOIC-16	188650-001	
U605	TDA7313, VOL CONT, DIP 28/SO28	177983	

ELECTRICAL PART LIST



Filters

Reference Designator	Description	Part Number	Note
CF300	FILTER, CER, 10.7MHZ, 230kHz	253037-002	
CF301	FILTER, CER, 10.7MHZ, 180kHz, FGD	253037-001	
CF302	RESONATOR, CERAMIC, 456kHz	187604-001	
CF303	CRYSTAL, FUND, 7.2MHZ, HC-49/S	250892-001	
CF401	RESONATOR, CER, 8 MHZ	191446-8R00	
CF500	CRYSTAL, 16.9344MHZ, HC-49/S	193415-001	
T300	DETECTOR, FM, SINGLE TUNED	187602-001	
T301	FILTER, CER, AM IF	187603-001	
T302	COIL, OSCILLATOR, AM	180647	
T303	FILTER, STEREO MPX, SINGLE TUNED	187624-001	
T304	FILTER, STEREO MPX, SINGLE TUNED	187624-001	

Inductors

Reference Designator	Description	Part Number	Note
L1	2.2uH, COMMON MODE	187598-2R2	3 
L2	2.2uH, COMMON MODE	187598-2R2	3 
L3	BEAD, 17.5MM	170179	
L4	BEAD, 17.5MM	170179	
L300	400 OHMS, CHIP, 0805	188587-401	
L400	400 OHMS, CHIP, 0805	188587-401	
L401	400 OHMS, CHIP, 0805	188587-401	
L402	400 OHMS, CHIP, 0805	188587-401	
L403	400 OHMS, CHIP, 0805	188587-401	
L404	400 OHMS, CHIP, 0805	188587-401	

Miscellaneous

Reference Designator	Description	Part Number	Note
FM-TUNER	TUNER, FM, 87.5TO 108 MHZ, SHIELD TUNER, FM, 4 GANG, 7V TUNER, FM, 76-90MHZ, 7V	251054 184589 188466-001	4 5, 6 7
F1	FUSE, 1.0 A, 250V FUSE, 0.5A, 250V, SLOBLO	135677-05 135677-03	3, 4, 7  3, 6, 7
VFD	DISPLAY, VFD, 4-GRID	251147	
J1	HEADER, LOCKING, TOP-ENTRY	193369-002	3 

[F1 CHANGED FROM .75A \(135677-04\) TO 1.0A, ECN 29009](#)

ELECTRICAL PART LIST

Miscellaneous (continued)

Reference Designator	Description	Part Number	Note
J2	CONN, HEADER, 5.0MM, 5A, 2 PIN	191946-002	3 
J3	CONN, HEADER, 8 POS	148591-08	3
J5	HEADER, PCB MNT, 2 POS	193422-002	
J6	HEADER, PCB MNT, 2 POS	193422-002	
J200	CABLE, BATTERY/ADAPTER, 9 VOLT	187610-001	
J300	FM ANTENNA, F-TYPE	193453	4, 7
J300	FM ANTENNA, PAL TYPE	193455	5, 6
J301	RECEPTACLE, TOP-ENTRY	191423-21	
J400	CONN, HEADER, 3 POS	148591-03	
J401	HEADER, RTANG, 21 PIN, FCC	191169-21	
J402	HEADER, RTANG, 21 PIN, FCC	191169-21	
J403	HEADER, RTANG, 15 PIN, WHITE	191169-15	
J500	HEADER, 13P, TOP-ENTRY, ZIF	193368-013	9, 10
J501	RECEPTACLE, TOP-ENTRY	191423-21	
J502	HEADER, LOW CURRENT 6 POLE	133224-06	
J600	CONN, HOUSING, PHONO, QUAD	149959	
FOR-D401	SPACER, LED	193426	
FOR-Q401	SPACER, LED	193426	
FOR-U300	SHIELD, IC	178944	
AM-ANT	ANTENNA, FERRITE BAR	177268	
	SCREW, TAPP, M3.5x0.6x10, PAN, TRX	140447-10	
	CLIP, SPRING	142864	
	HEATSINK	177562	
	SHIELD, BOTTOM, DISPLAY PCB	198610	
	HOLDER, VFD	199955	



J500

CONN, HEADER, 13P, TOP-ENTRY, SMT

253356-T13

11

PACKAGING PART LIST

Item Number	Description	Part Number	Qty.	Note
1	CARTON, RSC	199479-001	1	
2	PACKING, THERMO TRAY, TOP	250843	1	
3	PACKING, THERMO TRAY, BOTTOM	250844	1	
-	REMOTE, IMPERIAL WHITE REMOTE, PLATINUM WHITE REMOTE, GRAPHITE GREY	193334-001 193334-010 193334-002	1	
-	BATTERY, LITHIUM	180991	1	3 
-	BATTERY, 9V, CARBON	187609-001	1	3 
-	VELCRO, HOOK AND LOOP, MATED	188463-001	1	
-	CD, DEMO, US	193340	1	
-	LETTER, COMMITMENT	251001	1	
-	MANUAL, OWNER'S, ENGLISH MANUAL, OWNER'S, 4 LANG.	250723 251771	1	4 5, 6
-	ANTENNA, FM, DIPOLE, PAL CONN ANTENNA, FM DIPOLE, 75 OHM, F CONN	143185 148589	1	5, 6 4, 7, 8
-	SHEET, QUICK START, 120V QUICK START, 230V/240V	250722 251772	1	
-	CABLE, AUDIO, 2 POS, BLK	183879-02	1	
-	BAG, POLY, 14.38 x 9.87 x 2mil	103351	1	
-	BROCHURE, ALL PRODUCT	188898	1	
-	WARRANTY CARD	251497	1	
-	DECLARATION OF CONFORMITY	251918	1	
-	SHEET, BUFFER	251743	1	

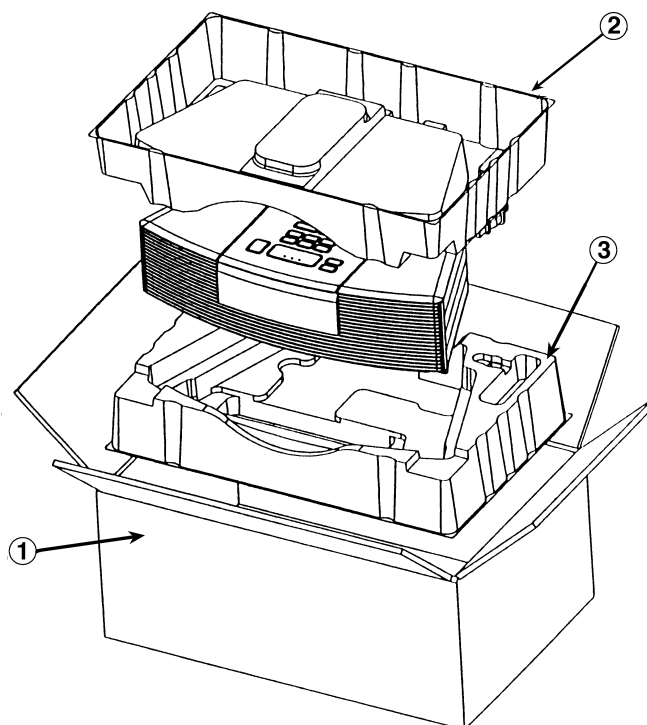

Figure 4. Packaging View

ABBREVIATED OPERATING INSTRUCTIONS

Note: Refer to the Bose® Wave® Radio/CD owner's guide 250723 for complete operating instructions.

To turn off the display- With the system off, hold down **CD Mode** and press **On/Off** to turn off the main display. The display only lights briefly when you press any button and while the alarm is sounding. Repeat this step to turn the main display back on.

To set AM/PM (12 hour) or Military (24 hour) time- With the system off, hold down **Alarm Setup** and press **On/Off** to switch between AM/PM (12 hour) and Military (24 hour) time formats.

To adjust the display brightness- The display dims automatically to medium or low brightness, as appropriate for low light room conditions. You can adjust the brightness setting of the display for both strong light and lowest light environments, but not for the medium light setting. Turn the system off before setting the brightness levels.

- In a strong lit room, hold down **CD Mode** and press **Volume up or down** to adjust the setting between 6 and 9 (it is preset to 8).
- In a barely lit room, hold down **CD Mode** and press **Volume up or down** to adjust the setting between 1 and 6 (it is preset to 2).
- If you do not want the system to dim automatically, set both levels to 5.

To manually tune in a station- Tap either **Track/Tune** button quickly two or more times to tune the frequency in small step. Or, press and hold either **Track/Tune** button until the desired station is reached. Then, you can press the button to adjust the frequency in small steps. After manually tuning, wait two seconds for the system to return to seek mode.

To set the alarm volume- While the selected alarm is flashing, press **Volume up or down** to set the alarm volume, from 10 to 99. The selected alarm flashes for ten seconds.

To set continuous music- In CD play mode, to select a source to play automatically after the CD ends, hold down **Alarm Setup** and press **FM, AM, or AUX** on the control panel only. The selected source lights briefly on the display. Cancel continuous play by pressing CD stop or On/Off.

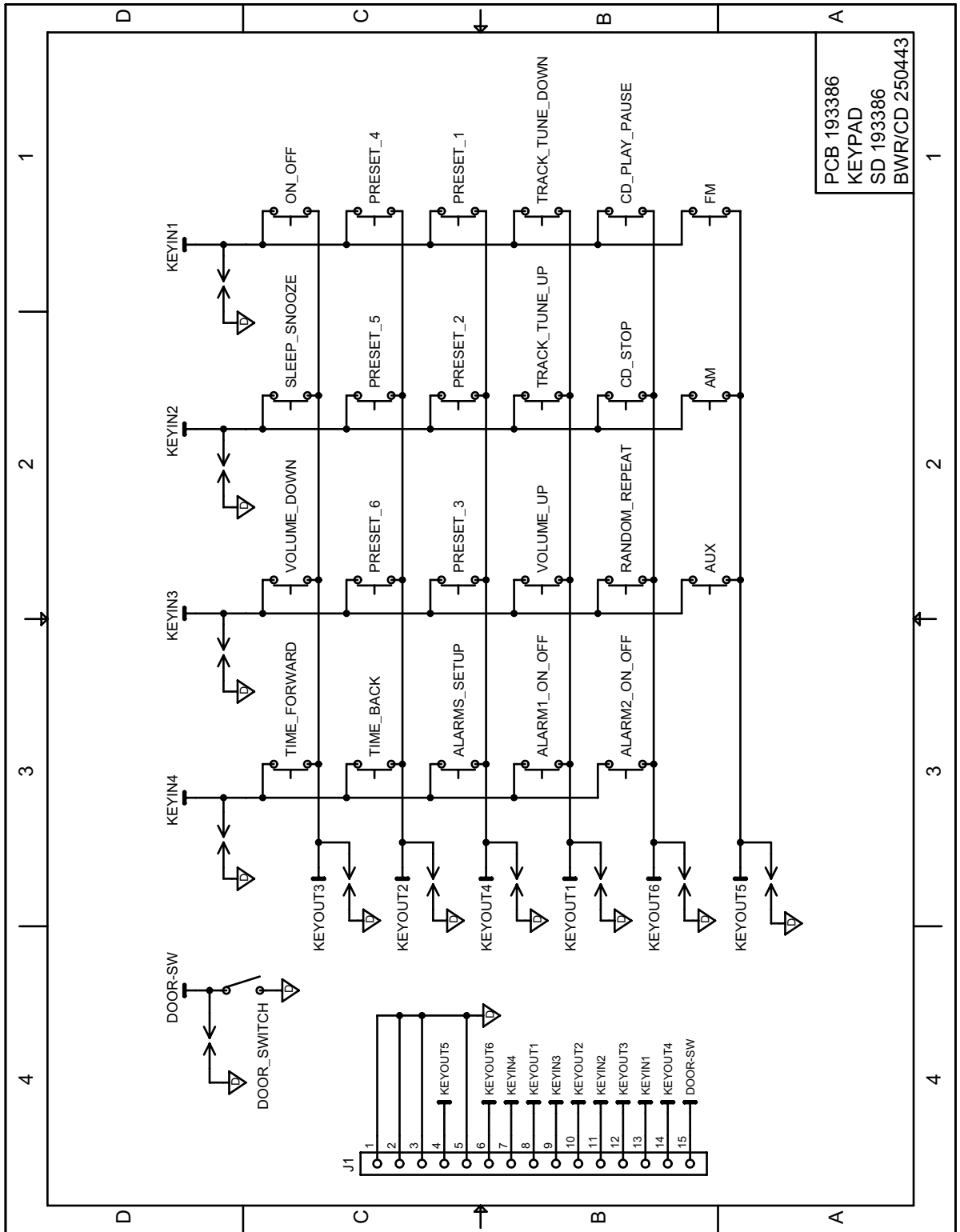

Figure 5. Keyboard Schematic Diagram

Bose® Wave® Radio/CD

100V/120V/230V/240V
PCB193325 and 252178



[Click here to go to the
table of Contents](#)

Specifications and Features Subject to Change Without Notice

BOSE®
Better sound through research®

Bose Corporation
The Mountain
Framingham Massachusetts USA 01701
P/N 250443 REV. 04 10/99 For Technical Assistance or Part Orders, Call 1-800-367-4008