

# HA1457

## HIGH VOLTAGE LOW NOISE PREAMPLIFIER

The HITACHI HA1457 is a monolithic integrated circuit mainly developed for the pre-amplifier for use in a Hi-Fi stereo tuner set and has the following features:

- Low Noise (RIAA Characteristic  $R_g = 3.3k\Omega$ , Input Conversion Noise  $0.88V$  typ,  $BW = 20Hz$  to  $20kHz$ ) Wide Dynamic Input Range of  $245mV_{rms}$  ( $f = 1kHz$ , T.H.D. =  $0.1\%$ ,  $G_V = 35.6dB$ ) due to its high voltage resistant capability. ( $\pm 25V_{max}$ . under double power supply,  $50V_{max}$ . under single power supply)
- High Stability against parasitic oscillations due to its new circuit system
- Operable as a high gain and low distortion amplifier due to its high open loop voltage gain ( $G_{V(OL)} = 99dB$  typ at  $f = 60Hz$ )
- Drivable down to low load due to its push-pull circuit at output stage (with output voltages up to  $15V_{rms}$ , operable in A class operation zone with in A class operation zone with load impedances down to  $10k\Omega$  and in B class operation zone with load impedances therebelow.)

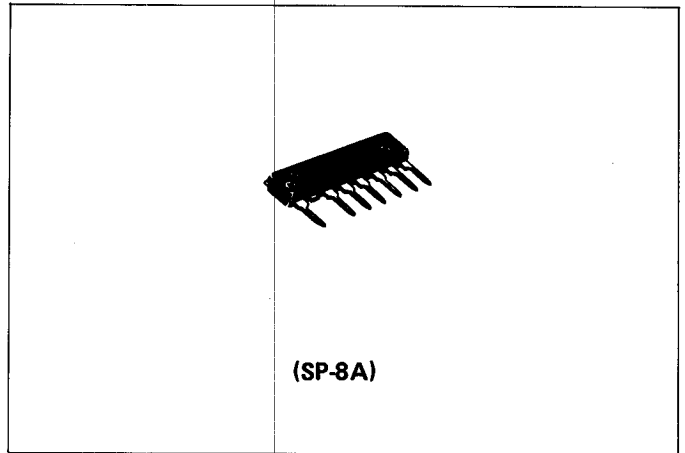

(SP-8A)

### ■ CIRCUIT SCHEMATIC AND TYPICAL APPLICATION CIRCUIT

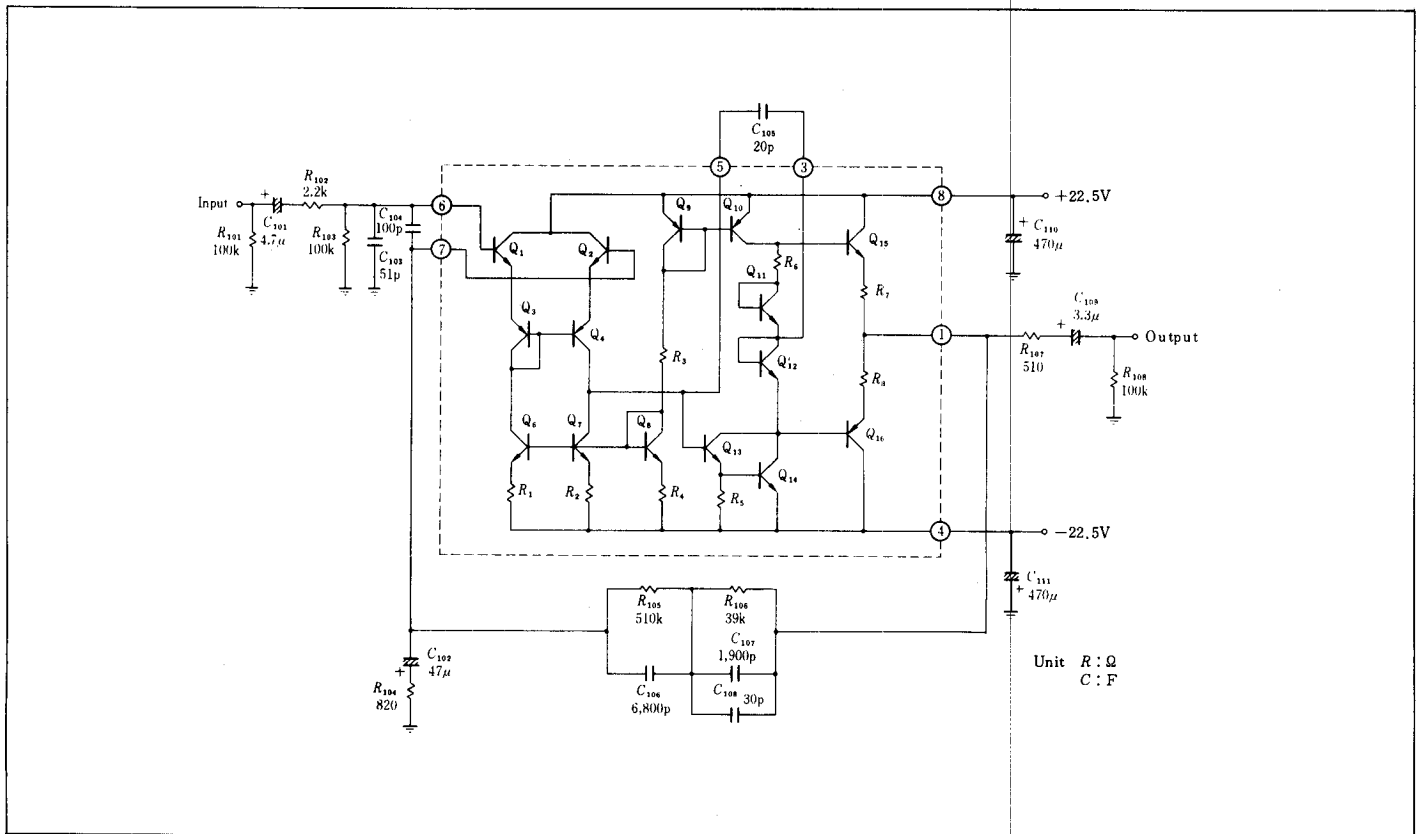

Unit R :  $\Omega$   
C : F

### ■ ABSOLUTE MAXIMUM RATINGS ( $T_a = 25^\circ C$ )

Item	Symbol	Rated	Unit
Supply Voltage	$V_{CC}$	$\pm 25$	V
Power Dissipation	$P_T^*$	500	mW
Operation Temperature	$T_{OP}$	$-30$ to $+75$	$^\circ C$
Storage Temperature	$T_{STG}$	$-55$ to $+125$	$^\circ C$

\* Value at  $T_a = 75^\circ C$

■ ELECTRICAL CHARACTERISTICS ( $V_{CC} = 22.5V$ ,  $T_a = 25^\circ C$ )

Item	Symbol	Test Condition	min	typ	max	Unit
Quiescent Current	$I_Q$	at Zero Signal	—	4.3	—	mA
Voltage Gain (Open loop)	$G_{V(OL)}$	$f = 1kHz$	75	82	—	dB
Output Voltage	$V_{out}$	$f = 1kHz$ , $H.H.D = 0.1\%$ $T.$	13.0	14.8	—	V
Total Harmonic Distortion	$T.H.D$	$f = 1kHz$ , $V_{out} = 5V$	—	0.005	0.02	%
Output Noise Voltage	$V_n$	$R_o = 3.3k\Omega$ , $BW = 20Hz$ to $20kHz$	—	53	90	$\mu V$

■ TEST CIRCUIT

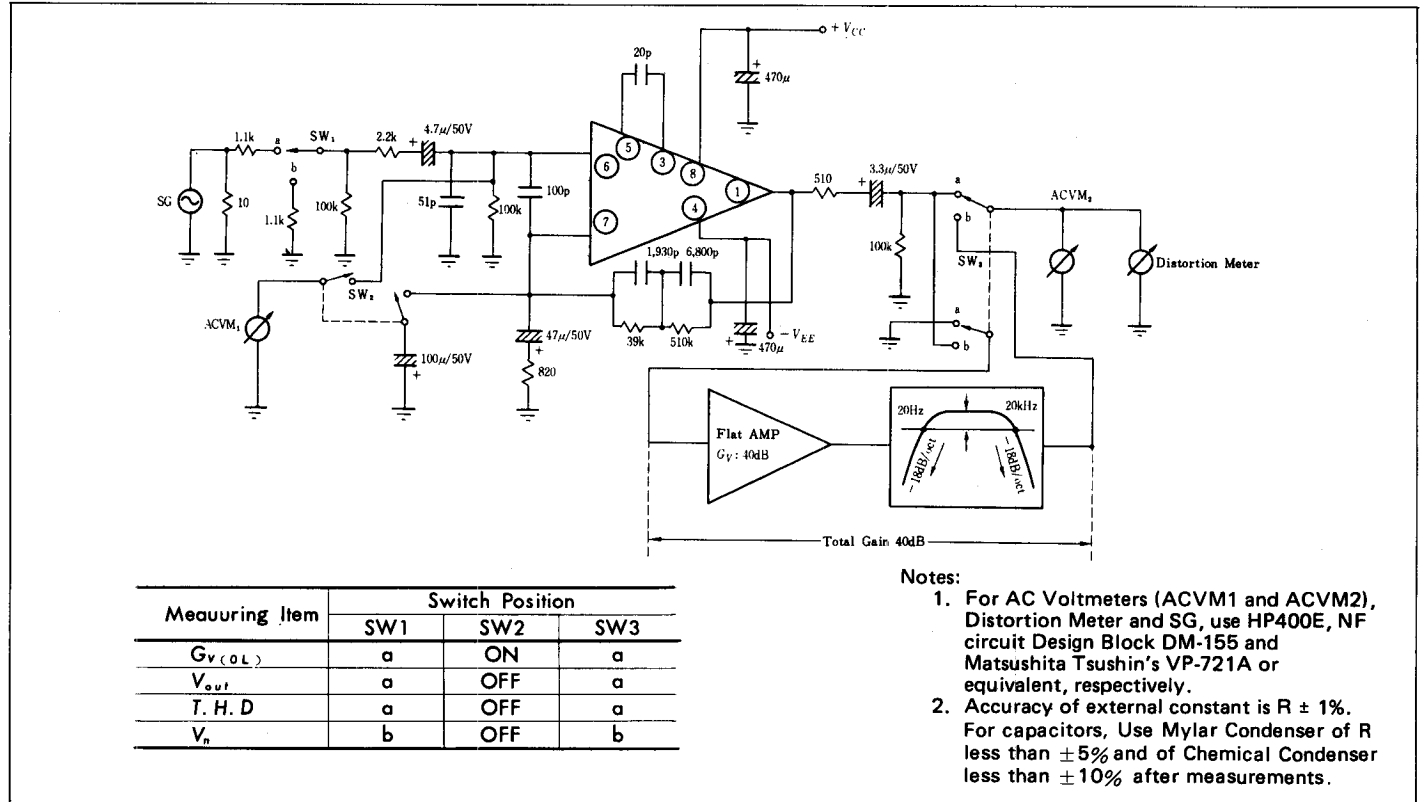

■ PC-BOARD LAYOUT PATTERN

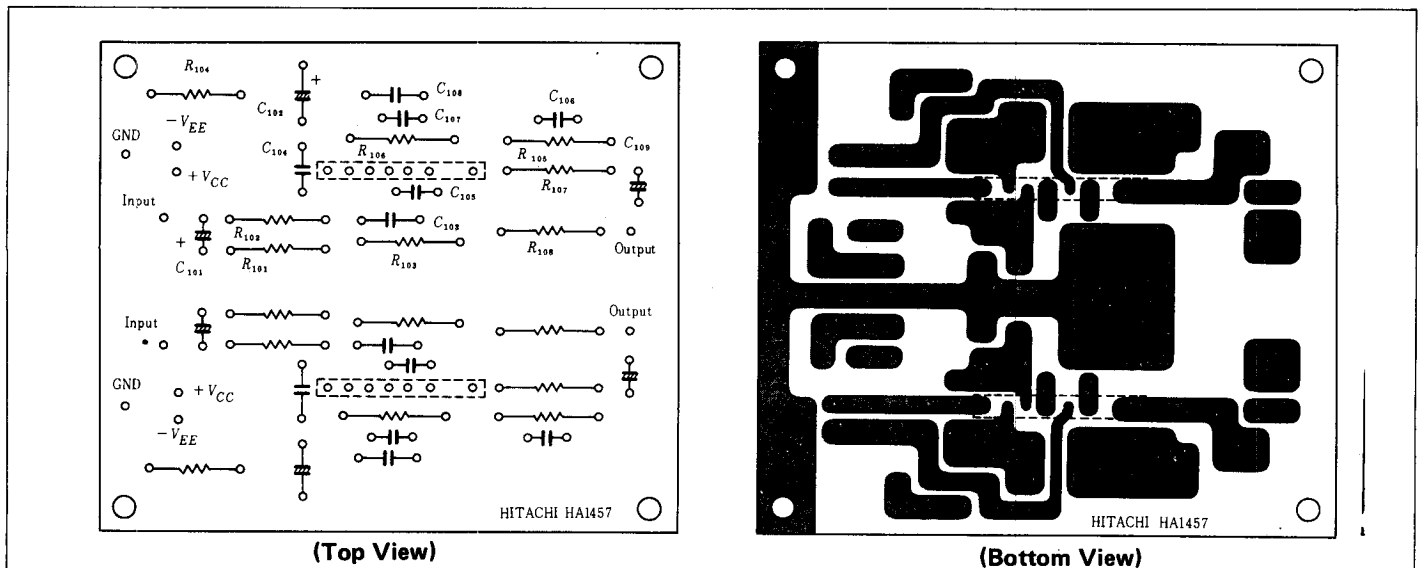

## ■ GUIDE FOR SELECTION OF EXTERNAL ELEMENT

### ● Condenser

#### C<sub>101</sub>

This condenser is an input coupling type. As the gain is high at low frequencies in the RIAA equalizer amplifier, 1/f noise of transistor is emphasized within the IC as output noise. Therefore, when the reactance of the condenser increases at low frequencies, the output noise is worsened by the signal source resistance dependability of 1/f noise. For this reason, it is necessary to make the reactance sufficiently small as compared to the signal source resistance. About 4.7μF is proper for the condenser, and the withstand voltage needs to be more than V<sub>CC</sub> (V<sub>EE</sub>). Also, leak current should be at a minimum. It is necessary to select a condenser in consideration of the foregoing.

#### C<sub>102</sub>

Low cut-off frequency is determined by the capacitance of this condenser. The low boost is made by the RIAA equalizer, and the low voltage gain is dictated by (R<sub>105</sub> + R<sub>106</sub>)/R<sub>104</sub> assuming that the frequency (low cut-off frequency) that makes the gain -3dB is now f<sub>L</sub>, the condenser C<sub>102</sub> is given by

$$C_{102} = \frac{1}{2\pi f_L \cdot R_{104}} \text{ [F]}$$

When C<sub>103</sub> = 47μF and R<sub>104</sub> = 820Ω, f<sub>L</sub> becomes about 4Hz.

#### C<sub>103</sub>

This condenser is used for broadening the oscillation margin such as in blocking oscillation at the time of large amplitude operation at high frequencies (above 20kHz).

(It has a multiplication effect with C<sub>104</sub>.)

When the frequency is lowered to an extreme extent, parasitic oscillation may be caused. So a condenser of 51pF should be inserted in that case.

#### C<sub>104</sub>

This is a condenser for the detection of frequencies in TV, FM, or AM broadcasting with high electric field.

A condenser with 100pF or so will be most proper as it may affect the margin for parasitic oscillation. (A combined use of R<sub>102</sub> and C<sub>103</sub> serves to make frequency detection based on the effect of low-pass filter up to the IC input pin.)

#### C<sub>105</sub>

This condenser is a phase compensating type of main feedback loop design. About 20pF is most proper because it may more or less affect the distortion factor at the time of large amplitude operation at high frequencies (above 20kHz).

#### C<sub>106</sub>, C<sub>107</sub>, and C<sub>108</sub>

The frequency characteristics of the equalizer amplifier is determined by this condenser and R<sub>105</sub>, R<sub>106</sub>. To obtain standard RIAA characteristics, for example, C<sub>106</sub>, R<sub>105</sub> = 3180μs and C<sub>106</sub>, R<sub>106</sub> = 318μs, and (C<sub>107</sub> + C<sub>108</sub>) = 75μs.

#### C<sub>110</sub>, C<sub>111</sub>

This is a by-pass condenser for power line. It is suggested to insert a condenser with good high frequency characteristics (above several μF) at a point as near to the power supply pin as possible.

### ● Resistor

#### R<sub>101</sub>

This resistor is used for C<sub>101</sub> leak current pass. Also, it serves to determine the input resistance R<sub>in</sub>. Thus

$$R_{in} = R_{101} // (R_{102} + R_{103})$$

#### R<sub>102</sub>

This resistor is intended to protect IC from abnormal input, parasitic oscillation due to various signal source impedance characteristics, and to step down the voltage to prevent high frequency radio disturbance. When the voltage is dropped to an extreme extent, it is probable sometimes that the oscillation is caused at the time of power turn off.

#### R<sub>103</sub>

This is a resistor for d-c bias of the input pin 6. It determines the input resistance, described in the section of R<sub>101</sub>.

#### R<sub>104</sub>

This is a feedback resistor which determines the voltage gain. Also, this resistor constitutes an important factor in determining the output noise voltage as it becomes the signal source resistance of the initial stage amplifier and consequently causes thermal noise. Increasing the resistance results in disadvantage for low noise realization.

#### R<sub>105</sub>, R<sub>106</sub>

This resistor is used in combination with the C<sub>106</sub>, C<sub>107</sub>, or C<sub>108</sub> to determine RIAA characteristics.

#### R<sub>107</sub>

This resistor is used for prevention of parasitic oscillation under a capacitive load.

#### R<sub>108</sub>

This resistor is intended to hold the output terminal to the d-c reference level. Without use of this resistor, a shock noise is bound to be generated at the time of set function switching.

## INPUT CONVERSION NOISE VOLTAGE VS. SIGNAL SOURCE RESISTANCE

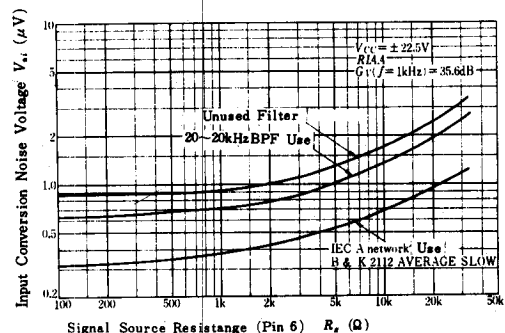

TOTAL HARMONIC DISTORTION VS. OUTPUT VOLTAGE

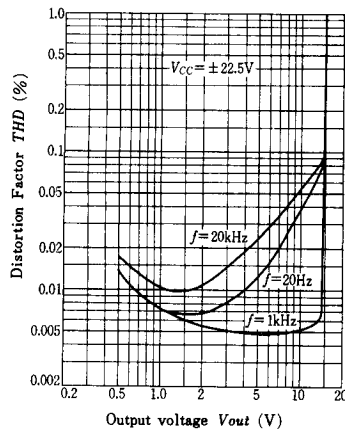

OPEN LOOP VOLTAGE GAIN VS. FREQUENCY

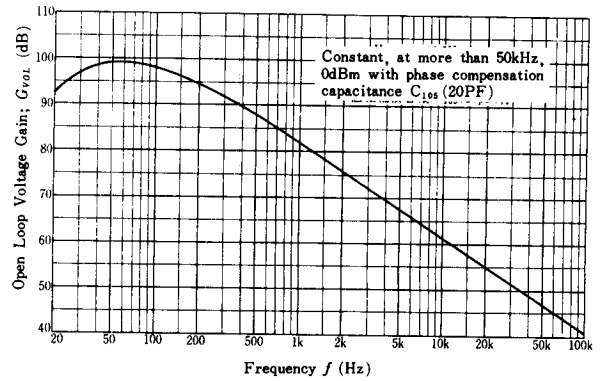

VOLTAGE GAIN VS. FREQUENCY

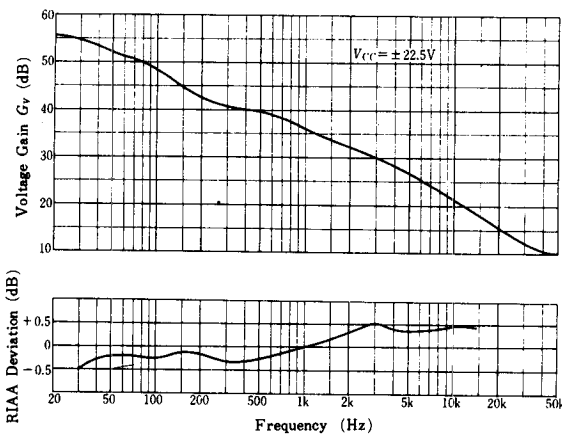

VOLTAGE GAIN VS. FREQUENCY

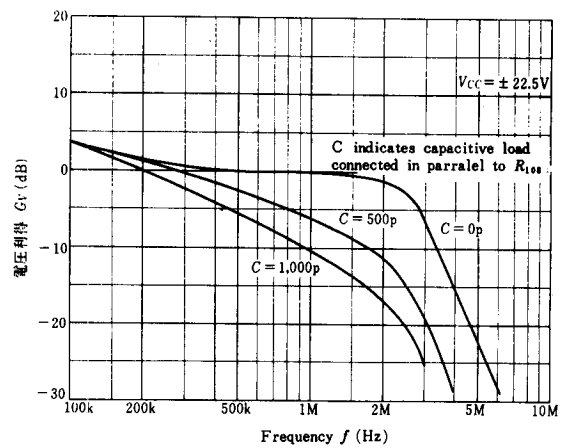

OUTPUT VOLTAGE VS. FREQUENCY

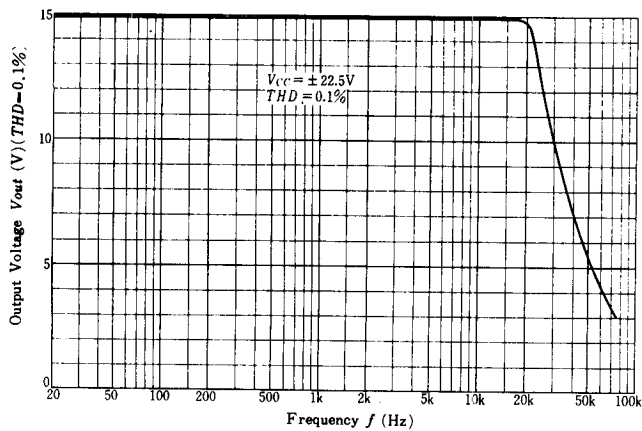

TOTAL HARMONIC DISTORTION VS. FREQUENCY

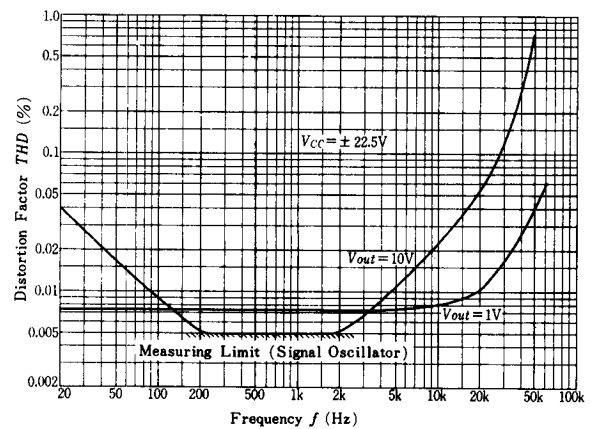

## HUM REJECTION VS. FREQUENCY

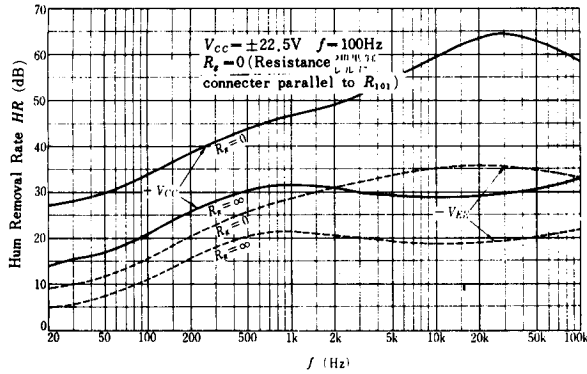

## INPUT CONVERSION NOISE VOLTAGE VS. SUPPLY VOLTAGE

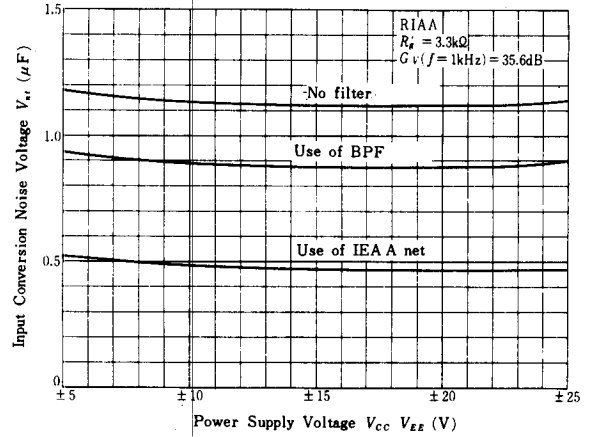

## TOTAL HARMONIC DISTORTION VS. SUPPLY VOLTAGE

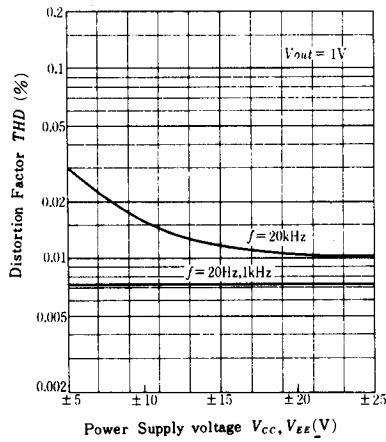

## OPEN-LOOP VOLTAGE GAIN VS. POWER SUPPLY VOLTAGE

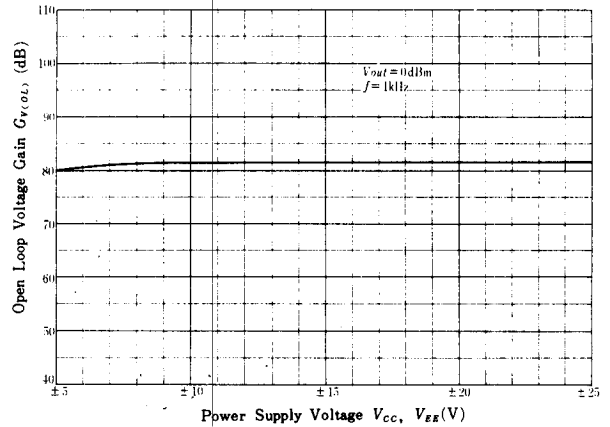

## OUTPUT VOLTAGE VS. SUPPLY VOLTAGE

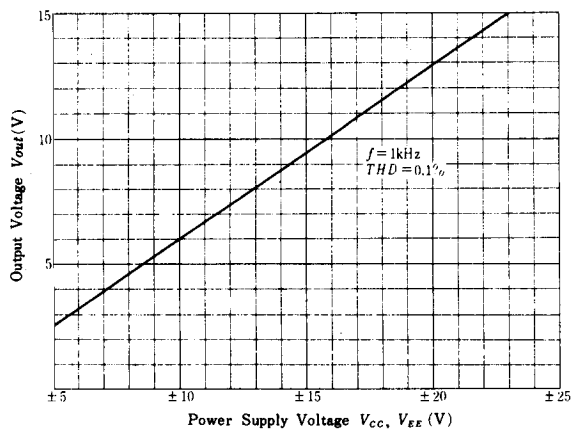

## HUM REJECTION RATIO VS. SUPPLY VOLTAGE

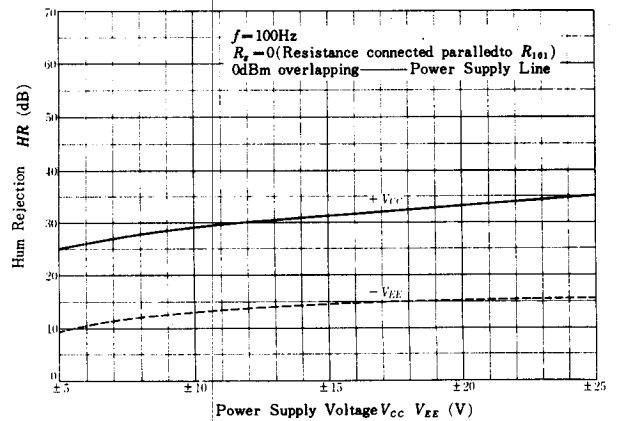

## QUIESCENT CURRENT VS. SUPPLY VOLTAGE

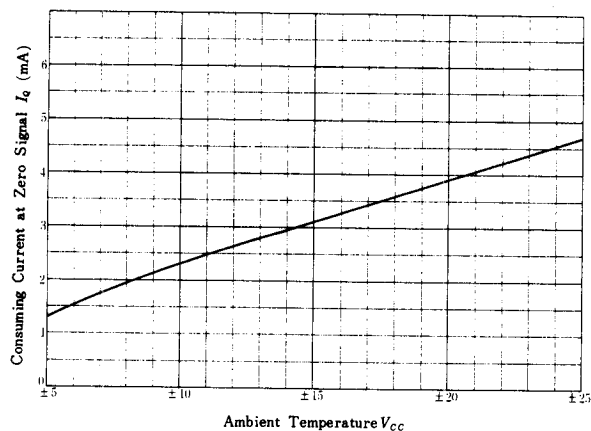

## INPUT CONVERSION NOISE VOLTAGE VS. SUPPLY VOLTAGE

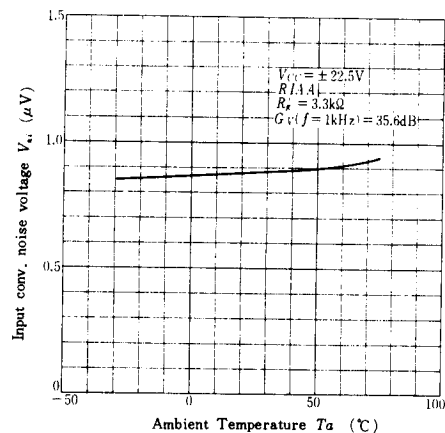

## TOTAL HARMONIC DISTORTION VS. SUPPLY VOLTAGE

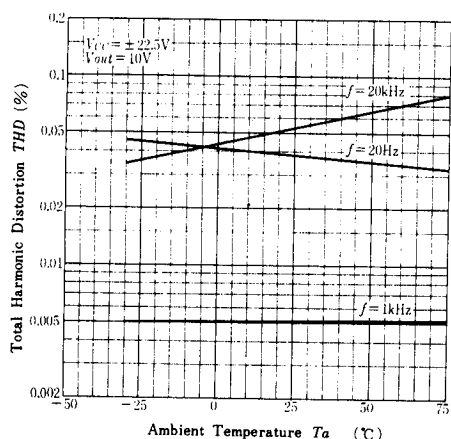

## OPEN-LOOP VOLTAGE GAIN VS. AMBIENT TEMPERATURE

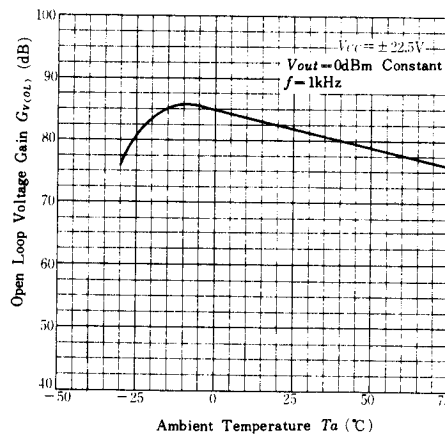

## HUM REJECTION RATIO VS. AMBIENT TEMPERATURE

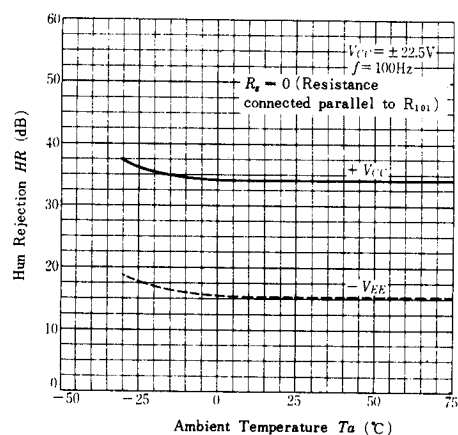

## QUIESCENT CURRENT VS. AMBIENT TEMPERATURE

